



CONSTRUCTION  
INDUSTRY COUNCIL  
建造業議會



# GUIDELINES ON SAFETY OF LIFT SHAFT WORKS

VOLUME 1 – DURING CONSTRUCTION STAGE AND BEFORE  
HANDING OVER TO LIFT INSTALLATION CONTRACTOR

## **Preface**

The Construction Industry Council (CIC) is committed to seeking continuous improvement in all aspects of the construction industry in Hong Kong. To achieve this aim, the CIC forms Committees, Task Forces and other forums to review specific areas of work with the intention of producing Guidelines, Codes of Practice and Codes of Conduct to assist participants in the industry to strive for excellence.

The CIC appreciates that some improvements and practices can be implemented immediately whilst others may take more time to complete the adjustment. It is for this reason that three separate categories of communication have been adopted, the purpose of which is as follows:

### **Guidelines**

These are intended to guide industry participants to adopt new standards, methodologies or practices. The CIC strongly recommends the adoption of these Guidelines by industry stakeholders where appropriate.

### **Codes of Practice**

The CIC expects all industry participants to adopt the recommendations set out in such Codes as soon as practicable and to adhere to such standards or procedures therein at all times.

### **Codes of Conduct**

The CIC encourages the upholding of professionalism and integrity within the industry through self discipline. The Codes of Conduct set out the relevant principles that all industry participants are expected to follow.

The Labour Department has agreed to make reference to the content of this publication when enforcing the relevant safety legislation.

If you have attempted to follow this publication, we do urge you to share your feedback with us in order that we can further enhance them for the benefit of all concerned. On this basis the CIC Secretariat is in the process of developing a “feed-back” mechanism, whereby your views can be consolidated for such purposes. With our joint efforts, we believe our construction industry will develop further and will continue to prosper for years to come.

## **Disclaimer**

*This publication is prepared by the Construction Industry Council (CIC) to report findings or promote good practices on specific subjects for reference by the industry but is NOT intended to constitute any professional advice on these or any other subjects. The parties using this publication should therefore seek appropriate advice from their professional advisers. The CIC (including its members and employees) will NOT accept responsibilities for any consequences resulting from the use of or failure to use this publication. The parties adopting the practices set out in this publication will normally be considered by the CIC in general as adopting good practices (where relevant) on the specific subjects.*

## **Enquiries**

Enquiries on these guidelines may be made to the CIC Secretariat at –

Room 2001, 20/F, Alliance Building  
130 – 136 Connaught Road Central  
Hong Kong

Tel. No. : (852) 3571 8716  
Fax. No. : (852) 3571 9848  
E-mail : [enquiry@hkcic.org](mailto:enquiry@hkcic.org)  
Website : [www.hkcic.org](http://www.hkcic.org)

© 2010 All rights reserved by the CIC.

# **Guidelines on Safety of Lift Shaft Works**

## **(Volume 1 – During Construction Stage and Before Handing Over to Lift Installation Contractor)**

---

### **1. Purpose**

- 1.1 This publication (Volume 1) sets out the good practices recommended by the Construction Industry Council (CIC) for enhancing work safety of site personnel working near or inside a lift shaft during the construction stage and before handing-over to the lift installation contractor. Three volumes of publications covering various stages are outlined below -

Volume 1 – During Construction Stage and Before Handing Over to Lift Installation Contractor

Volume 2 – During Lift Installation Stage Until Issue of Occupation Permit (OP) and Handing Over to Developer

Volume 3 – Throughout Occupation Stage

### **2. Definitions**

- 2.1 In this publication, unless the context otherwise specifies –
- (a) “Contractor”, in relation to construction work, means any person or firm engaged in carrying out construction work by way of trade or business, either on his own account or pursuant to a contract or arrangement entered into with another person, including the private sector, the Government of the Hong Kong Special Administrative Region or any public body;
  - (b) “Lift shaft platform” serves as a rain shelter, a formwork platform to construct lift shaft walls, a mid-shaft platform to protect the lift well, a debris-catching platform, or a crash deck.

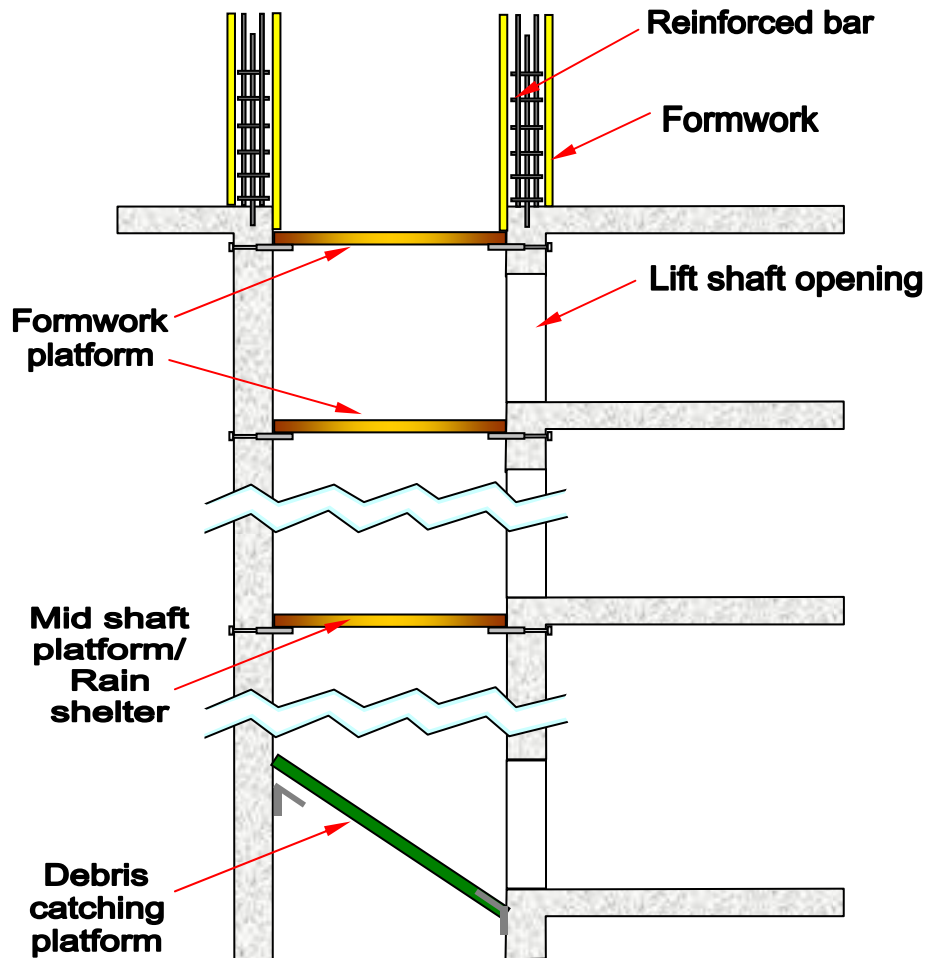

Figure 1: Various types of lift shaft platforms

- (c) “Lift shaft work” should include but not limited to:–
- (i) formwork erection, concreting and formwork stripping of lift shaft walls;
  - (ii) making-good of lift shaft walls;
  - (iii) erection, maintenance and dismantling of scaffolds;
  - (iv) erection, alteration, maintenance and dismantling of lift shaft platforms;
  - (v) materials and equipment lifting inside lift shafts;
  - (vi) refuse removal/water pumping at lift pit;
  - (vii) construction of concrete plinths at lift pit; and
  - (viii) miscellaneous builder works such as erection of cat ladder or metal stage platform.

- (d) “Technically Competent Person (TCP)” means a person possessing academic or professional qualifications and experience of building works or street works that satisfy the requirements set out in the Code of Practice for Site Supervision issued by the Buildings Department for a particular type of site supervision or management tasks;
- (e) “Contractor’s Engineer” means a person holding a qualification of TCP T4 or above and appointed by the Contractor for the supervision and management of construction works.
- (f) “Registered Structural Engineer (RSE)” means a person whose name is for the time being on the structural engineers' register kept under section 3(3) of the Buildings Ordinance (Chapter 123).

### **3. Introduction**

- 3.1 Nowadays, most of the buildings and such construction projects involve lift installation. The construction of lift shafts and the subsequent lift installation processes necessitate the attention of all project stakeholders to ensure site safety. This publication will focus on the precautionary measures recommended for enhancing the safety of lift shaft works before handing over to the lift installation contractor.
- 3.2 This publication promotes safe practices for lift shaft works, with reference to core ingredients of a safe system of work in the principles of risk elimination, hazard reduction, accident prevention and protection of workers.
- 3.3 In developing and implementing a safe system of work for any lift shaft works, the Contractor should observe and comply with other requirements governing the safety aspects of various items of lift shaft works stipulated under the Ordinance(s), Practice Notes and Code(s) of Practice as listed in Annex A.

#### **4. Limitations**

- 4.1 It is important to note that compliance with this publication does not of itself confer immunity from legal obligations in Hong Kong. Employers or contractors are reminded to observe and comply with statutory provisions, relevant codes of practice and all other government departments' requirements so as to discharge their legal and other pertinent duties in respect of construction works and other uses associated with the lift shafts.
- 4.2 Any standards, procedures, forms, or specifications stipulated in this publication are by no means exhaustive. The Contractor should critically examine their applicability and suitability taking into account the actual site conditions and the specific safety hazards of the project.

#### **5. Safe System of Work on Lift Shaft Works**

- 5.1 To ensure the safety and health of workers engaged in lift shaft works, the Contractor should:
- (a) plan the lift shaft works (paragraph 6 refers);
  - (b) provide lift shaft protection (paragraph 7 refers);
  - (c) conduct a risk assessment and prepare a method statement on any lift shaft work (paragraph 8 refers);
  - (d) design, construct, use and maintain lift shaft platforms properly (paragraph 9 refers);
  - (e) develop and implement a permit-to-work system for any lift shaft work for close supervision on the adoption of safety precautions (paragraph 10 refers);

- (f) provide fall-arrest system and safety training to workers (paragraph 11 refers); and
- (g) pay special attention to buildings under Temporary Occupational Permit (TOP) arrangement (paragraph 12 refers).

## **6. Planning of Lift Shaft Works**

- 6.1 The Contractor should plan all lift shaft works to ensure that each type of lift shaft work is carried out safely and independently. He should address carefully the need and work arrangement of any lift shaft work to be carried out and to cater for situation where a portion of the building would be occupied with the issue of a TOP, including all necessary safety features and provisions. For details, please refer to paragraph 12 below.
- 6.2 Lift shaft works underneath lift shaft platforms should be avoided as far as practicable. Whenever there is a need to carry out a lift shaft work, the Contractor should thoroughly review the necessity and arrangement of the works and consider any alternative for completing the works without going into the lift shaft. The Contractor should assess the need in the following assessment steps:-



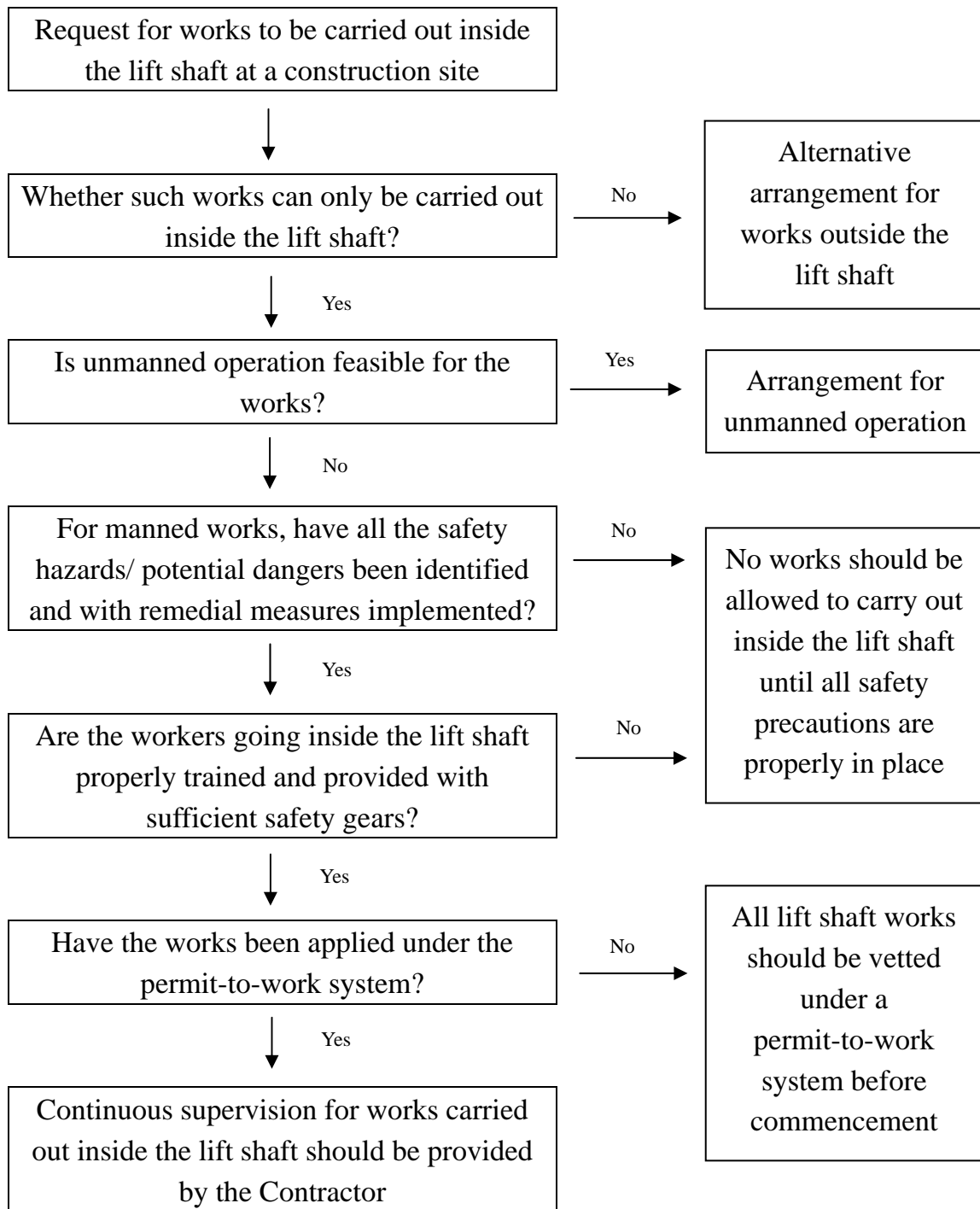

Figure 2: Assessment steps on the need to carry out lift shaft works

6.3 At planning stage, the following exceptionally high risk conditions should be addressed critically:

- (a) it is strongly advisable NOT to allow a lift shaft to be used as a refuse chute. Where necessary, proper temporary refuse chutes should be provided and maintained for the purpose. If practicably unavoidable and the lift shaft is used for refuse handling purpose, under no circumstance should any person be allowed to enter into the lift shaft at any time. Protective fences/ guardrails should be properly installed to ensure that rubbish/ debris can be cleared without endangering the lives of the workers. There should be sufficient solid barrier and restraint to prevent workers from entering the lift shaft.

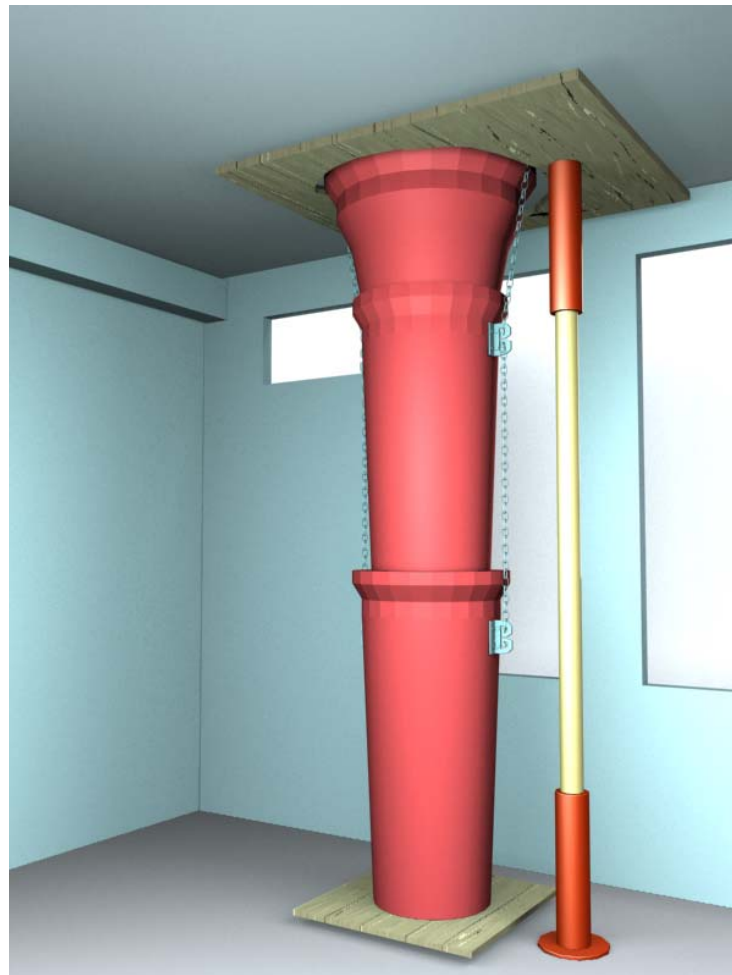

Figure 3: A temporary refuse chute

- (b) it is strongly advisable NOT to use lift shafts to house material hoists or for material transportation by lifting appliances. If practically unavoidable and there is a need to use a lift shaft for these purposes, the planning should include the design and construction of proper landing platforms with interlocking gates at lift shaft door openings and the structural assessment of anchorages of lifting appliances.
  - (c) when floors with unfinished lift shaft works will be occupied after the issue of TOP, additional lift shaft protection should be designed in building planning stage and submitted by the Authorized Person to the Building Authority for acceptance/ approval before application of TOP. The occupant should be kept informed of the designated lift shaft works and observe/ maintain the related arrangements/ protection including safe means of access (for workers only) to the lift shafts. Please refer to paragraph 12 for details;
- 6.4 A planning team comprised of site managerial and supervisory representatives from main contractor and subcontractors such as project manager, project engineer, site agent, registered safety officer (RSO), Contractor's Engineer and general foreman of the Contractor, with at least one of them holding TCP T4 or equivalent qualifications, and the related personnel including subcontractor's representatives who will be involved in the lift shaft works should be lined up to participate in the planning process. The plan should be properly documented by the RSO.
- 6.5 The plan should identify the job responsibility and duty of each member of the planning team.

## **7. Provision of Lift Shaft Protection**

- 7.1 Before the commencement lift shaft works, all openings to a lift shaft such as landing or access openings should be fenced off by installation of temporary steel covers or gates to prevent materials falling from landing floors to lift shafts. The construction of the steel covers or gates should comply with the following requirements:-

- (a) function as a protection against fall of persons and falling objects through lift shaft openings from the respective floor levels;
- (b) be closed at all times and could be locked from outside. However, it should be readily open from the inside of lift shafts at any time without the need of separate key operations;

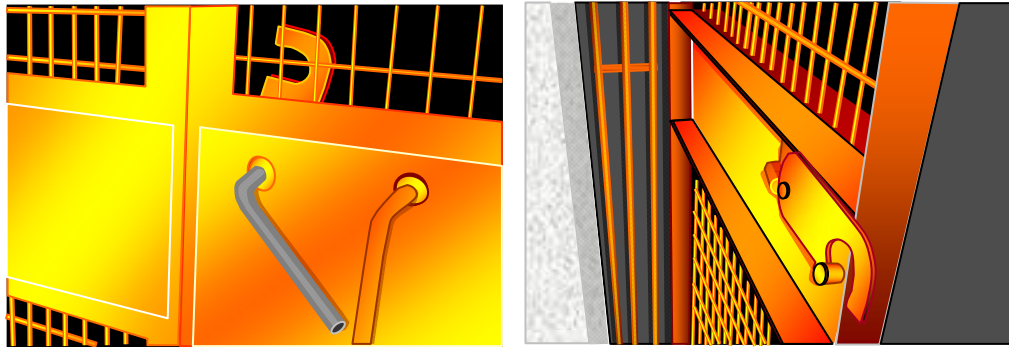

Figure 4: Locking device of landing door

- (c) provide full-height temporary steel barrier to lift shaft opening

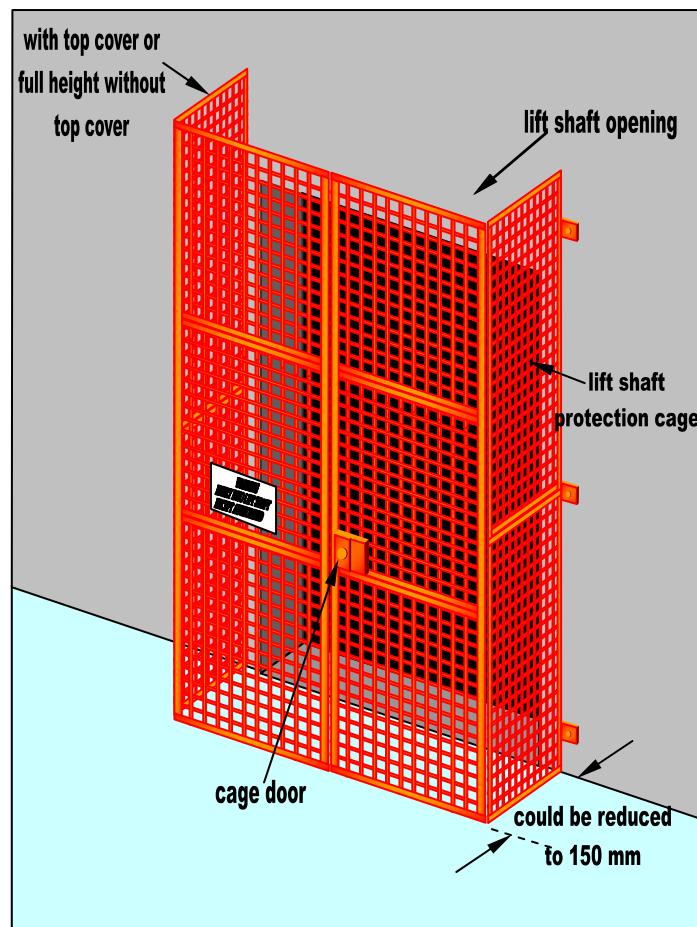

Figure 5: Lift shaft protection cage

- (d) use mesh size for steel barrier: maximum 50mm x 50mm;
  - (e) provide suitable railing with toe board at each opening. No part of the temporary steel barrier should obstruct the installation of the permanent lift doors and architraves and ramp at lift shaft entrance; and
  - (f) design and maintain the temporary steel barrier to operate in a proper, efficient and safe manner (such as smaller steel barrier panels to enable ease of installation and safety at all times).
- 7.2 Temporary steel gates should be maintained in a proper, efficient and safe manner for operation. Implement proper safety measures to protect against falling from height at all times. When the steel barriers are no longer required, they should be dismantled and cleared away properly and safely.
- 7.3 Place warning notices and safe working procedures near lift shaft openings at prominent locations to remind all site personnel to take all necessary safety precautions when entering the lift shaft.



Figure 6: Warning notice

- 7.4 For openings above lift shaft in lift machine room, they should be protected by ferrule or concrete curb and covered up with fixed wooden board or metal plate. Ventilation openings should also be covered with mesh and reinforcement.

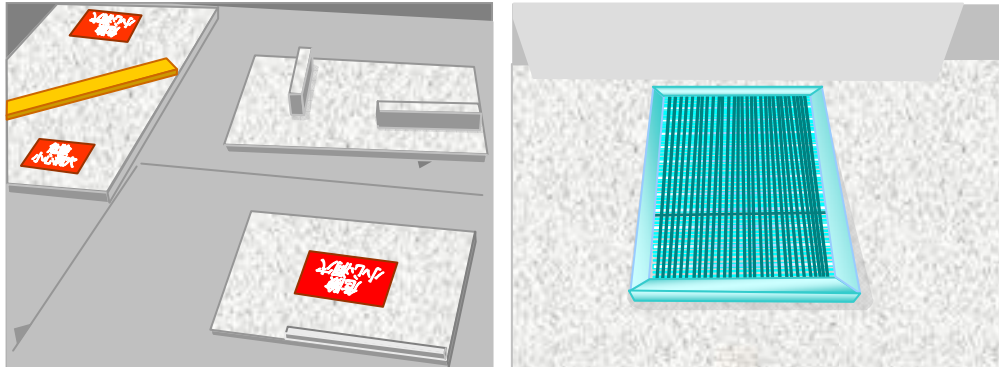

Figure 7: Covers of floor openings in lift machine room

- 7.5 As far as practicable, suitable debris net/ mesh inside lift shafts against falling objects should be erected according to the following requirements:-
- (a) net eyes should not be larger than 20mm x 20mm; and
  - (b) the debris net/ mesh should be installed at an interval not more than 20m in height.
- 7.6 Temporary electric power supply with power source should be provided close to the lift shaft. The power should be compatible with the use of 110V electric powered hand-tools.
- 7.7 The earthing should be properly connected when metal scaffolding is used inside a lift shaft.
- 7.8 Provision of adequate illumination for lift shaft works by installation of 110V temporary lighting connected to an isolating transformer having the centre tap of the secondary winding earthed.
- 7.9 All of the above items, even if not in-use, should be maintained in a functional and effective manner at any time during construction works.

## **8. Risk Assessment and Method Statement**

- 8.1 As an essence of a safe system of work, a risk assessment should be conducted by the planning team formed under paragraph 6.4 on each type of lift shaft works except formwork erection, concreting and formwork stripping of lift shaft walls. The RSO should be consulted for completeness of the risk assessment process.
- 8.2 The assessment should include but not limited to hazards related to falling objects, fall-from-height, collapse of platform/ supporting structures for platform or lifting appliances, defective lifting appliance and lifting gear, absence of lighting and ventilation, etc as are relevant to the erection, use, relocation and dismantling of the type of platforms proposed to be used. With reference to each procedural step of a lift shaft work, the assessment should recommend safety precautions and state the person responsible to execute the safety measures. The risk assessment report should be signed by the RSO and endorsed by a project manager or a site agent of the Contractor.
- 8.3 In conducting the assessment, the following should be carefully identified, addressed with suitable safety precautions, recorded for implementation as appropriate: -
- (a) Provide safe means of access to and egress from each place of work. For example, there should be safe access to and egress from the lift shaft openings, etc;
  - (b) Put in place rescue procedures and evacuation arrangement in case of fire, explosion, accident or other emergency situations, etc. occurring in any part of the building during the works;
  - (c) Keep to minimum the number of persons working within a lift shaft at the same time to the extent that simultaneous working at two different levels is strongly NOT advisable;
  - (d) Provide communication equipment for use by the working personnel during the works, and specify key words/signals for clarity of use during communication; and

- (e) Clearly stipulate the arrangements and procedures for safe manual handling operations which will be taking place during the work.

8.4 Method statements for each type of lift shaft works should be prepared, taking into consideration all safety measures from the risk assessment report. The related precautionary measures should be disseminated to all relevant parties to ensure that they are properly understood and followed. A sample of the risk assessment report for a particular lift shaft work is provided at Annex B for reference.

## **9. Design, Construction, Use and Maintenance of Lift Shaft Platforms**

9.1 Every lift shaft platform should be properly designed by a RSE employed by the Contractor. The design plan should contain all the necessary details and specifications of the platform and should be kept available on site for inspection by the Labour Department (LD). The Contractor should display at each platform location a notice in both English and Chinese stating the designed use and the allowable imposed load in terms of weight per square metre.

9.2 A construction plan containing method statements on the erection, alteration, maintenance and dismantling of lift shaft platforms should be prepared by the Contractor's Engineer and checked and signed-off by the RSE employed by the Contractor. The method statement should prescribe how the platform is transported by lifting appliances from floor to floor safely.

9.3 Every lift shaft platform should be erected, and/or dismantled in accordance with the construction plans prepared by the Contractor's Engineer. The work should be carried out under the immediate full-time supervision of a competent person with TCP T1 qualifications appointed in writing by the Contractor. Upon completion, the works should be checked by the Contractor's Engineer. A record should be kept of the date of erection/dismantling of each platform and the name of the person who supervised the works. This record should also be made available on site for inspection by LD.



- 9.4 Any alteration to the lift shaft platform should be designed by the RSE employed by the Contractor while the construction plans and method statements for the alteration works should be prepared by the Contractor's Engineer and checked and signed-off by the RSE employed by the Contractor.
- 9.5 Every lift shaft platform should be properly maintained by regular cleaning to prevent the accumulation of debris. Steps should be taken to ensure that no materials and debris are thrown, tipped or shot down onto a lift shaft platform unless the platform has been designed in the form of a crash deck for such purpose by the RSE employed by the Contractor.
- 9.6 It is strongly advisable NOT to allow simultaneous working at two different levels. If practicably unavoidable, a lift shaft platform might be designed and constructed in double decks. Steps should be taken to ensure the decks should be correctly and firmly supported by wall anchors before the platform is put into use. In all cases, inter-deck ladder should not be allowed.

## **10. Implementation of a Permit-to-Work System**

- 10.1 A permit-to-work system should be developed and implemented for any lift shaft works. A checklist containing the safety measures from the risk assessment report of a lift shaft work and a permit-to-work certificate should be developed by an RSO (a site RSO or an RSO in consultation with the planning team) and executed by a Builders Responsible Person. The Builders Responsible Person should be at the foreman level or above, with possession of (i) training certificate of construction safety supervisor course, AND (ii) TCP T1 qualifications and at least 5 years of related work experience, OR (iii) at least 10 years of related work experience.
- 10.2 The permit-to-work certificate for a particular lift shaft work should record the following:
- (a) the findings in the risk assessment report;
  - (b) the effectiveness of the isolation and withdrawal from service;

- (c) the nature of work to be done;
  - (d) the condition and safety precautions in the work place; and
  - (e) the period during which workers may remain safely in the lift shaft.
- 10.3 A sample of the certificate for a particular lift shaft work is depicted in Annex C.
- 10.4 The permit-to-work system should also outline a tight control on the access to a lift shaft.
- 10.5 Access to lift shaft should be strictly confined to workers or other personnel who have attended suitable technical and safety training, in particular in the use of personal protective equipment and the identification of hazards on working at heights. Unauthorized entry into the lift shaft should be strictly prohibited.
- 10.6 It is strongly advisable NOT to allow more than one sub-contractor to have access to the lift shaft at the same time. If concurrent access of a lift shaft by more than one (sub)contractor is practicably unavoidable, a permit-to-work certificate should only be issued on those working space properly separated and protected by crash deck(s).

## **11. Provision of fall-arrest system and safety training**

- 11.1 The Contractor should provide and maintain sufficient fall-arrest system for the use of workers engaged in the erection, maintenance and dismantling of lift shaft platforms and for workers engaged in any type of lift shaft works.
- 11.2 The fall-arrest system should contain an independent lifeline, a lanyard and a full body harness for each worker. The independent lifeline should be securely anchored to a wall anchor or a wall structure.
- 11.3 No worker should enter or work inside a lift shaft to perform the aforesaid lift shaft work without wearing a safety harness attached to an independent lifeline.

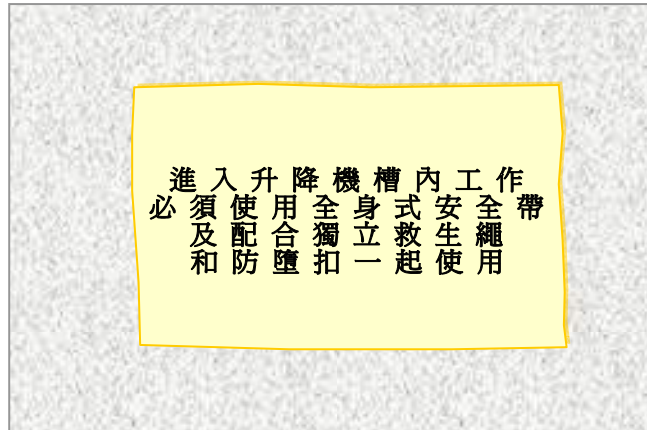

Figure 8: Warning notice to wear safety harness

- 11.4 Before the commencement of any lift shaft works, workers engaged in any lift shaft work should be briefed on the findings of the risk assessment report, the safety procedural steps of a method statement and the implementation of a permit-to-work system.
- 11.5 The safety and health training should include drills on steps and procedures to be followed in case of emergency or accident as part of the safety and health training. Records of safety training should be properly kept.

## 12 Special Attention to Buildings under TOP Arrangement

- 12.1 If TOP arrangement is to be adopted, all the necessary safety features and provisions should be considered in the planning and design stage. Temporary safety measures such as access to lift shafts and areas not yet occupied during TOP should also be planned, designed and provided.
- 12.2 All conditions imposed in the TOP (having regard to the TOP boundary plan accepted/ approved by the Building Authority) including precautionary measures (e.g. fire separation of adequate fire resistant period between occupied and construction areas) must be fulfilled and maintained accordingly at all times until full OP is issued.

12.3 The fire separation, including lift shaft walls if any, between the occupied area and the construction area must remain entirely intact at all times to prevent cross spread of fire, particularly if works are being carried out in the lift shaft. Hence any existing emergency access panel/door located in the lift shaft walls forming part of the fire separation should not be used for access to the lift shaft for carrying out lift shaft work. Also, any access to the lift shaft for the same purpose must not be formed in the fire separation and should be provided from the construction area instead. The design of such access should be catered for in the planning stage under paragraph 6.1 to ensure both prevention of fire spread and safety of workers.

12.4 High-rise or super high-rise buildings are more common nowadays and TOP for occupation of lower zone (can be up to 30-40 floors) may be needed by the developer. In such case, the lift shafts for high zone lifts (within construction area as lift shaft works not yet completed) would pass through many occupied floors. Notwithstanding paragraph 12.3, for practicality, safe access for the workers to work in such lift shafts to be provided from occupied area may be unavoidable in this scenario. In such circumstances:

- (a) to ensure fire safety, additional or alternative lift shaft protection to maintain adequate fire separation at all times between the occupied area and construction area should be designed and submitted by the Authorized Person of the development project to the Building Authority for acceptance/ approval, preferably to be indicated in the TOP Boundary Plan before application of TOP. Any fire separation (including that to enclose a lift shaft) should not be erected to cause any obstruction or reduction in width of any escape route of the occupied areas. Any temporary facility/ installation including scaffoldings, formworks, platforms, plankings and strutting etc. inside such lift shafts should be constructed of non-combustible materials;
- (b) for safety of occupants, the Contractor should co-ordinate with relevant parties (e.g. owner/developer, occupant, management office, etc.) and ensure that:
  - (i) the enclosure around the lift shaft and opening, serving as fire separation, should be of adequate fire resistance period. Any access

door in the enclosure (both doors for a fire protected lobby) should be of adequate fire resistance period, self closing, closed and locked from outside at all times but readily open from inside without key;

- (ii) an alarm signal would be sent to the Contractor's site office when the access door in the enclosure is in an open position so that action can be taken to ensure the access door be promptly restored to the closed position;
  - (iii) a warning sign (e.g. DANGER - No entry into the construction area unless authorized. Keep door closed.) be placed at prominent locations on the outermost access door and walls of the enclosure and that the building management should be requested to bring this to the attention of the occupants;
  - (iv) apart from the above safety precautionary measures for the access door and enclosure, the protection of the lift shaft opening in accordance with paragraph 7 be implemented;
  - (v) the supervisor/holder of the permit-to-work and workers be reminded to ensure the access doors in the fire rated enclosure be in closed and locked position immediately after entering and leaving the enclosure; and
  - (vi) independent daily check on the closing and locking functions of the access door mentioned above be carried out;
- (c) to ensure workers' safety, Contractor should appoint an RSO (with work experience in confined space for one year or above) to conduct a specific risk assessment on whether the portion of a lift shaft inside the TOP boundary is a confined space. The assessment should stipulate safety measures to be adopted in a method statement. A permit-to-work system should be administered and monitored by the RSO. In no circumstance, should:
- (i) gas cutting and electric welding be conducted in the portion of the lift shaft inside the TOP boundary; and

(ii) shaft protection under TOP be altered or removed without the prior approval from the Authorized Person.

12.5 Should the lower portion of a particular lift shaft be within the TOP boundary, any horizontal separation between this portion and the upper portion must be of adequate structural strength and fire resistance period together with a warning sign stating the allowable imposed load. If the horizontal separation is intended to be used as a lift shaft platform, then it must also fulfil all the corresponding requirements in this publication.

### 13. Annexes

Annex A	List of Relevant Existing Legislation(s)/ Regulation(s) / Code(s) of Practice / Practice Notes.
Annex B	Sample of Job Hazard Analysis & Risk Assessment Report
Annex C	Sample of Permit to Work

**List of Relevant Existing Legislation(s)/ Regulation (s) and Code(s) of Practice**

1. Construction Sites (Safety) Regulations, Chapter 59I
2. The Lifts and Escalators (Safety) Ordinance, Chapter 327
3. Code of Practice on the Design and Construction of Lifts and Escalators, Electrical & Mechanical Services Department
4. PNAP ADV-10 (formerly PNAP 181) and PNRC 29
5. Code of Practice on Building Works for Lifts and Escalators, Buildings Department
6. Code of Practice for Lift Works and Escalator Works, Electrical & Mechanical Services Department
7. Code of Practice for Safety at Work (Lift and Escalator), Labour Department

## SAMPLE ASSESSMENT FORM

(NOTE: The content and format of this assessment form are for reference only. Persons responsible for the risk assessment of lift shaft works might make appropriate changes to the form to suit practical needs in relation to their projects.)

### Job Hazard Analysis & Risk Assessment Report

## Dismantling of Lift Shaft Platform Inside the Constructed Lift

## A Proposed Property Development

Risk Ass. No.	Date	Prepared By:	Checked By:	Agreed By:
	Effective date:			
Version: 1.0		<i>Name</i> (Title in Full)	<i>Name</i> (Title in Full)	<i>Name</i> (Title in Full)



## Risk Evaluation

### Frequency Classification:

Class	Frequency Categories Description
F1	Frequent – Once per month or more. More than 10 incidents per year (>10/yr).
F2	Common – Several times per year. 1 to 10 incidents per year (1/yr to 10/yr).
F3	Likely – Once every few years. 1 incident per year to once every 10 years (0.1/yr to 1/yr)
F4	Rare – Once or a few times within system lifetime. 1 incident per 10 year to once every 100 years (0.01yr to 0.1/yr)
F5	Unlikely – Do not expect to occur within system lifetime. 1 incident per 100 year to once every 1000 years ( $10^{-3}$ /yr to 0.01/yr)
F6	Improbable – Do not expect to occur beyond system lifetime. 1 incident per 1000 year to once every 10,000 years ( $10^{-4}$ /yr to $10^{-3}$ /yr)
F7	Incredible – Do not expect to occur. Less than once every 10,000 years ( $<10^{-4}$ /yr)

### Severity Classification:

Class	Safety Severity Categories Description
R	Service-Related – No direct effect on safety.
C1	Trivial – Any hazard that can lead to superficial injuries, which require first-aid treatment only.
C2	Minor – Any hazard that can lead to recoverable or soft tissue injuries, which are not Serious.
C3	Serious – Any hazard that can lead to amputation of a limb, a fracture or dislocation, internal injuries, loss of an eye, burns or any other injury of a kind which results in his being admitted to a hospital immediately following the accident for observation or treatment.  This consequence Class also includes hazards that can lead to occupational disease with long term or unrecoverable injury to sensory or internal organ, loss of sight, loss of hearing, etc. This consequence Class should also be assigned to a hazard that can lead to more than 15 Minor injuries in a single incident.
C4	Critical – Any hazard that can lead to fatalities (<15 person/incident), multiple serious injuries in one incident (>15 injured persons/incident), or numerous Minor injuries in one incident (>200 injured persons /incident).
C5	Disastrous – Any hazard that can lead to multiple (>15) fatalities or numerous Serious injuries in one incident (>200 injured persons/incident).

**Risk Matrix:**

<b>Risk Matrix</b>						
<b>Consequence Frequency</b>	<b>R-Service Related</b>	<b>C1-Trivial</b>	<b>C2-Minor</b>	<b>C3-Serious</b>	<b>C4-Critical</b>	<b>C5-Disastrous</b>
<b>F1-Frequent (&gt;10/yr)</b>	<b>R</b>	<b>B</b>	<b>A</b>	<b>A</b>	<b>A</b>	<b>A</b>
<b>F2-Common (1yr to 10/yr)</b>	<b>R</b>	<b>B</b>	<b>B</b>	<b>A</b>	<b>A</b>	<b>A</b>
<b>F3-Likely (0.1/yr to 1/yr)</b>	<b>R</b>	<b>C</b>	<b>B</b>	<b>A</b>	<b>A</b>	<b>A</b>
<b>F4-Rare (0.01/r to 0.1/yr)</b>	<b>R</b>	<b>C</b>	<b>C</b>	<b>B</b>	<b>A</b>	<b>A</b>
<b>F5-Unlikely (10-3/yr to 0.01/yr)</b>	<b>R</b>	<b>D</b>	<b>C</b>	<b>C</b>	<b>B</b>	<b>A</b>
<b>F6-Improbable (10-4/yr to 10-3/yr)</b>	<b>R</b>	<b>D</b>	<b>D</b>	<b>C</b>	<b>C</b>	<b>B</b>
<b>F7 – Incredible (&lt;10-4/yr)</b>	<b>R</b>	<b>D</b>	<b>D</b>	<b>D</b>	<b>C</b>	<b>C</b>

**Risk Class Description:**

<b>Risk Class</b>	<b>Description</b>
<b>A</b>	High Risk – Risk control measures should be implemented to mitigate the risk to a level that is ALARP with a top priority.
<b>B</b>	Medium Risk – Cost-effective risk control measures should be implemented to mitigate the risk to a level that is ALARP within a reasonable time.
<b>C</b>	Low Risk – Cost-effective risk control measures should be implemented to mitigate the risk to a level that is ALARP with a low priority.
<b>D</b>	Negligible Risk – Risk is considered acceptable; no additional risk control action is normally required. Cost-effective risk control measures may be implemented to further mitigate the risk with the lowest priority.
<b>E</b>	Hazard Eliminated – Hazard has been eliminated at source or no longer exists. For project-based hazard logs, this also includes hazards that do not exist within the project scope.

**Priority of safety precautionary measure:****High (H) - Degree of Risk in Risk Class A**

1. Review the work procedure immediately; 立即檢討施工程序
2. Formulate safety measures to reduce the risk to “Low” level; 執行安全措施，將風險減到最低
3. Supervision by competent person. 由合資格人士監督

**Medium (M) - Degree of Risk in Risk Class B**

1. Review the work procedures within reasonable time. 在合理時間內檢討施工程序
2. Formulate safety measures to reduce the risk to “Low” level. 執行安全措施，將風險減到最低

**Low (L) - Degree of Risk in Risk Class C to E**

1. Follow in-house safety rules and statutory requirements. 遵守內部安全守則及法例

**Note 註:** If the control measures are unable to reduce the risk to “Low” level 如控制措施不能將風險減到最低:

1. The method statement shall be reviewed by the engineer; 施工程序必須由工程師檢討
2. Re-assess the risk according to the revised method statement and procedures. 按照修正後的施工程序再作風險評估

## Risk Assessment Report 風險評估報告

Project : A Proposed Property Development

Report No. :

Effective Date :

Activity : Dismantling of Lift Shaft Platform, Page 1 of 4

Date of Review :

Prepared By :

Item 項目	Activities/ Locations 工序 / 地點	Hazard 危害	Degree 程度			Control Measures 控制措施	Action 執行	Personal Protective Equipment 個人防護 用具	Training 訓練	Original Risk 原有風險	Residual Risk 剩餘風險
			Likelihood 可能性	Consequence 嚴重性	Risk 風險						
1	Construction planning and selection of person employed on dismantling of temporary lift shaft metal platform inside the constructed lift	Unfamiliar with site environment; Unfamiliar with the hazards associated with the task and start working without authorization on site;	<b>F4</b>	<b>C3</b>	<b>B</b>	<ol style="list-style-type: none"> <li>The dismantling of the lift shaft platform should strictly follow the dismantling sequence and drawing.</li> <li>The trade worker should carry the drawing which mark with dismantling sequence every time with him on work.</li> <li>Appointed trade worker for dismantling task should receive special training and briefing by MC &amp; S/C.</li> <li>Only S/C appointed trade worker should carry the task. S/C should report to MC if there is any change or substitute of worker.</li> <li>Repeat items 1 to 4 by special training or briefing for every NEW appointed trade worker for dismantling task.</li> <li>Planning of using safety harness(es) with energy absorber lanyard and D hook worn by appointed trade worker.</li> <li>Planning of reserved tie holes which specifically for the purpose of anchor point to secure 16 mm tie rope anchorage.</li> <li>Planning of appointed competent person for the dismantling work duties, which he shall supervise the trade worker doing his task and take record of the details.</li> </ol>	Design stage: Project Engineer + Senior Site Superintendent + S/C Site in charge + Competent Person + Safety Officers  Work stage: Area Foremen + S/C Site in charge + Competent Person + Trader Workers	safety helmet, safety shoes, safety harness, energy absorber lanyard, D hook	method statement briefing & (trade training) & use of safety harness	<b>B</b>	<b>A</b>

Project : A Proposed Property Development

Report No. :

Page 2 of 4

Item 項目	Activities/ Locations 工序 / 地點	Hazard 危害	Degree 程度			Control Measures 控制措施	Action 執行	Personal Protective Equipment 個人防護 用具	Training 訓練	Original Risk 原有風險	Residual Risk 剩餘風險
			Likelihood 可能性	Consequence 嚴重性	Risk 風險						
2.	Dismantling of lift shaft metal platform inside the constructed lift	Fall of person altogether with metal platform into the lift pit	<b>F3</b>	<b>C4</b>	<b>A</b>	<ol style="list-style-type: none"> <li>1. Competent person is duly to notify area foremen of the date, time and which lift shaft will undertake dismantling work.</li> <li>2. Warning notices should be displayed at one floor upper the lift shaft and one floor lower lift shaft to warn others.</li> <li>3. Secure 16 mm tie rope anchorage on the reserved tie holes which specifically for the purpose of an anchor point.</li> <li>4. Appointed trade worker shall wear safety harness(es) with energy absorber lanyard and D hook.</li> <li>5. Fence off the lift shaft area for dismantle work.</li> <li>6. The trade worker should strictly follow the drawing marks with dismantling sequence.</li> <li>7. Do not stack construction materials at the temporary platform during dismantling process.</li> <li>8. Always reserve spaces as escape access to the lift mouth.</li> <li>9. Appointed competent person for dismantling work shall supervise the trade worker doing his task and take record of the details.</li> <li>10. To install lighting if the constructed floor is relatively dark.</li> <li>11. Re-instate the lift door fencing after work. <b>Do not left it open unattended.</b></li> </ol>	Work stage: Area Foremen + S/C Site in charge + Competent Person + Trade Workers	safety helmet, safety shoes, safety harness, energy absorber lanyard, D hook	method statement briefing & (trade training) & use of safety harness	<b>A</b>	<b>B</b>

Item 項目	Activities/ Locations 工序 / 地點	Hazard 危害	Degree 程度			Control Measures 控制措施	Action 執行	Personal Protective Equipment 個人防護 用具	Training 訓練	Original Risk 原有風險	Residual Risk 剩餘風險
			Likelihood 可能性	Consequence 嚴重性	Risk 風險						
3	Dismantling of lift shaft metal platform inside the constructed lift	Fall of object from upper floor	<b>F4</b>	<b>C3</b>	<b>B</b>	<ol style="list-style-type: none"> <li>1. Competent person is duty to notify area foremen of the date, time and which lift shaft will undertake dismantling work.</li> <li>2. Warning notices should be displayed at one floor upper the lift shaft and one floor lower lift shaft to warn others.</li> <li>3. Any falling object occurs should STOP work immediately and report to Competent Person or Area Foremen.</li> <li>4. Do not stack construction materials at the temporary platform during dismantling process.</li> <li>5. SICOW to conduct end of shift inspection to make sure the lift door fencing and toe-board is reinstated after the work.</li> </ol>	Work stage: Area Foremen + S/C Site in charge + Competent Person + Trade Workers	safety helmet, safety shoes, safety harness, energy absorber lanyard, D hook	method statement briefing & (trade training) & use of safety harness	<b>B</b>	<b>A</b>
4	Dismantling of lift shaft metal platform inside the constructed lift	metal platform give way due to poor design or poor erection	<b>F3</b>	<b>C4</b>	<b>A</b>	<ol style="list-style-type: none"> <li>1. Construction of the lift shaft platform should strictly follow the design criteria approved in the method statement.</li> <li>2. Provision of the Y25 wall bracket support, and any other components of the lift shaft platform shall conform to the actual size and length in the design criteria.</li> <li>3. Appointed competent person for erection and dismantling work shall be same person. He must supervise the trade worker doing his task and take record of the details.</li> <li>4. No overloading or stacking of unnecessary construction materials in the temporary platform.</li> </ol>	Work stage: Area Foremen + S/C Site in charge + Competent Person + Trade Workers	safety helmet, safety shoes, safety harness, energy absorber lanyard, D hook	Pre-construction meeting; method statement briefing & (trade training)	<b>A</b>	<b>B</b>

Project : A Proposed Property Development

Report No. :

Page 4 of 4

Item 項目	Activities/ Locations 工序 / 地點	Hazard 危害	Degree 程度			Control Measures 控制措施	Action 執行	Personal Protective Equipment 個人防護 用具	Training 訓練	Original Risk 原有風險	Residual Risk 剩餘風險
			Likelihood 可能性	Consequence 嚴重性	Risk 風險						
5	Manual carrying of the construction materials due to area unreachable by cranes	Back injury	<b>F4</b>	<b>C2</b>	<b>C</b>	<ol style="list-style-type: none"> <li>1. Adopt correct posture to hand carry the construction materials.</li> <li>2. Some warm-up exercises before work commencement.</li> <li>3. Use trolleys or domestic cart for transporting goods and materials.</li> </ol>	Work stage: Competent Person + Trade Workers	safety helmet protective gloves & tagline for dragging	(Induction Training) & (Trade training)	<b>C</b>	<b>C</b>
6	Erection of side formwork and steel fixing of the lift shaft wall	Removal of the temporary platform members due to obstruction	<b>F4</b>	<b>C3</b>	<b>B</b>	<ol style="list-style-type: none"> <li>1. No use of temporary lift platform as the material cutting table.</li> <li>2. Flame cutting or portable cutting tool in the temporary platform should be avoided.</li> <li>3. Ensure that timber panels are shutter down firmly by adequate number of nails.</li> <li>4. No other construction activities should be carried out that it would affect the stability of the temporary platform.</li> <li>5. Inform Area Foremen for completion of work or end of shift.</li> </ol>	Work stage: Area Foremen + S/C Site in charge + Competent Person + Trade Workers	safety helmet & safety harness	(Induction Training) & (Trade training)	<b>B</b>	<b>A</b>

Note: The role and responsibility of the person as specified in the “Action” column should be properly defined in the Project Organization Chart.

**SAMPLE FORM****工作許可證 (升降機槽內工作)****Permit to Work (Work inside lift shaft)**

Permit No. 許可證號碼: \_\_\_\_\_

Project 地盤名稱 : \_\_\_\_\_

Location 工作地點 : (Lift shaft no. 升降機槽) (Floor 樓層)

Description of work 工作性質: \_\_\_\_\_

Company 公司 : \_\_\_\_\_ 日期 Date : \_\_\_\_\_

Permit valid from 許可工作由 : \_\_\_\_\_ hrs. to 至 : \_\_\_\_\_ hrs.

**Foreseeable hazards associated with the work 可預見危害:**

- Falling Objects 物料從高處下墮
- Fall of person 人體從高處下墮
- Insufficient Lighting 燈光不足
- Electric Shock 觸電
- Simultaneous working by different parties (e.g. workers, contractors) at two separate levels within the lift shaft 不同人士 (例如工人、承建商) 在升降機槽內兩個不同層面同時工作
- Other, please specify 其他, 請註明 \_\_\_\_\_

**Safety precautions taken 安全措施:**

- Suitable working platform w/valid CSSR-Form 5 檢驗合格的工作台及表格五
- Independent lifeline fixed to suitable anchorage point 繫扣於合適穩固點上的獨立救生繩
- Full body harness w/fall arrestor 全身式安全帶連防墮器
- Guardrail / Toe-board / Wire net 井口圍欄 / 踢腳板 / 防墮鐵網
- Safety helmet / Gloves / Eye-protector/ Ear-protector 安全帽 / 手套 / 眼罩 / 耳塞
- Warning signs 警告牌
- Portable lighting device 燈光設備
- Proper isolation of electricity and grounding 良好絕緣及接地
- Prominent display of work permit 於工作地點張掛工作許可證
- Catch Fence 防墮物屏障
- Other, please specify 其他, 請列明 \_\_\_\_\_

\*Ensure that all lift shaft openings above the working level are properly fenced off and completed with wire net and toe-board\*

\*確保工作地點上方之升降機槽口, 已經圍封及裝有防墮鐵網及踢腳板\*



**SAMPLE FORM****工作許可證**  
**Permit to Work**

Permit No. 許可證號碼: \_\_\_\_\_

**Certification 證明**

I certify that the above precautions have already been taken. I had briefed the safety procedures to all workers involved in the work and they will be strictly followed in the duration of the work.

本人證明前述安全措施已全部妥善執行。本人已清楚向下列工作人員講解有關安全工作步驟，並保證遵守。

Signature 簽名: \_\_\_\_\_

Permit holder (持有許可證人士) Builders Responsible Person (\*工程負責人)

(to be signed before commencement of works 開工前簽發)

**Acceptance of the Permit 接受有關許可證**

I have read and understood this Permit and shall undertake to work in accordance with all the conditions laid down in it.

本人已細閱及明白有關許可證，並承諾於工作中謹遵有關條款。

Signature 簽署: \_\_\_\_\_

Supervisor (監督人員)

Permit Holder (持有許可證人士)

**Details of the work team 工作人員資料:**

Supervisor 監督人員姓名: 1. \_\_\_\_\_, 2. \_\_\_\_\_

Workman 工作人員姓名: 1. \_\_\_\_\_, 2. \_\_\_\_\_, 3. \_\_\_\_\_

4. \_\_\_\_\_, 5. \_\_\_\_\_, 6. \_\_\_\_\_

7. \_\_\_\_\_, 8. \_\_\_\_\_, 9. \_\_\_\_\_

**Permit cancellation 撤銷許可證**

I certify that the work under this permit is completed. All workers, tools and equipment are cleared from the job area.

本人證明此許可證內所述之工作經已完成。全部工人、工具及物料已搬離工作地點。

Signature 簽署: \_\_\_\_\_

Supervisor (監督人員)

Permit Holder (持有許可證人士)

(to be signed upon completion of works 完工後簽發)

Remarks: \* Builders Responsible Person for the certification of the Permit-to-work should be at the foreman level or above.

備註: \* 工程負責人必須為管工級別或以上之人士，方可簽發。