



CONSTRUCTION
INDUSTRY COUNCIL
建造業議會

Partition (Metal Frame) Installer Skilled Trade Test Mock Practical Test Paper

此文件關於間隔(金屬骨架)工工藝測試考題。如有需要索取此文件的中文版本，請致電 2100 9232 與工藝測試中心聯絡。

Disclaimer

No part of this material may be reproduced or transmitted in any form or any means without the written permission of the CIC. Whilst reasonable efforts have been made to ensure the accuracy of the information contained in this material, the CIC nevertheless would encourage readers to seek appropriate independent advice from their professional advisers where possible and readers should not treat or rely on this material as a substitute for such professional advice for taking any relevant actions.

Enquiries

Enquiries on this Material may be made to the Trade Test Centre at:

95, Yue Kwong Road
Aberdeen
Hong Kong

Tel: (852) 2100 9232
Fax: (852) 2100 9249
Email: enquiry@hkcic.org
Website: www.hkcic.org

© 2015 Construction Industry Council.

Trade Test Paper

Job Title: Partition Installer (Metal Frame)

Grade: Skilled Worker

Test Topic: Complete the Following Work in accordance with Working Plans I, II & III at the designated location.

1. At the location designated by the testing centre, compose metal frame in accordance with the plans, leave door and window opening positions, and cut gyp board to seal walls in accordance with the plans and ink line levelling (Working Plans I & II). (80%)
2. Search for hidden pipes with a detector at the location specified by the Plan, and mark their positions (Working Plan III). (20%)

Testing Time: 4 Hours (Excluding Lunch Time)

Notes:

- (1) Before commencement of work, candidates must read the attached “Notice to Candidates”;
- (2) A candidate will be deemed as failed if he/she does not take appropriate safety measures in the testing process; and
- (3) The test paper consists of 5 pages with 100 points being the full score, and 60 and plus the passing one.

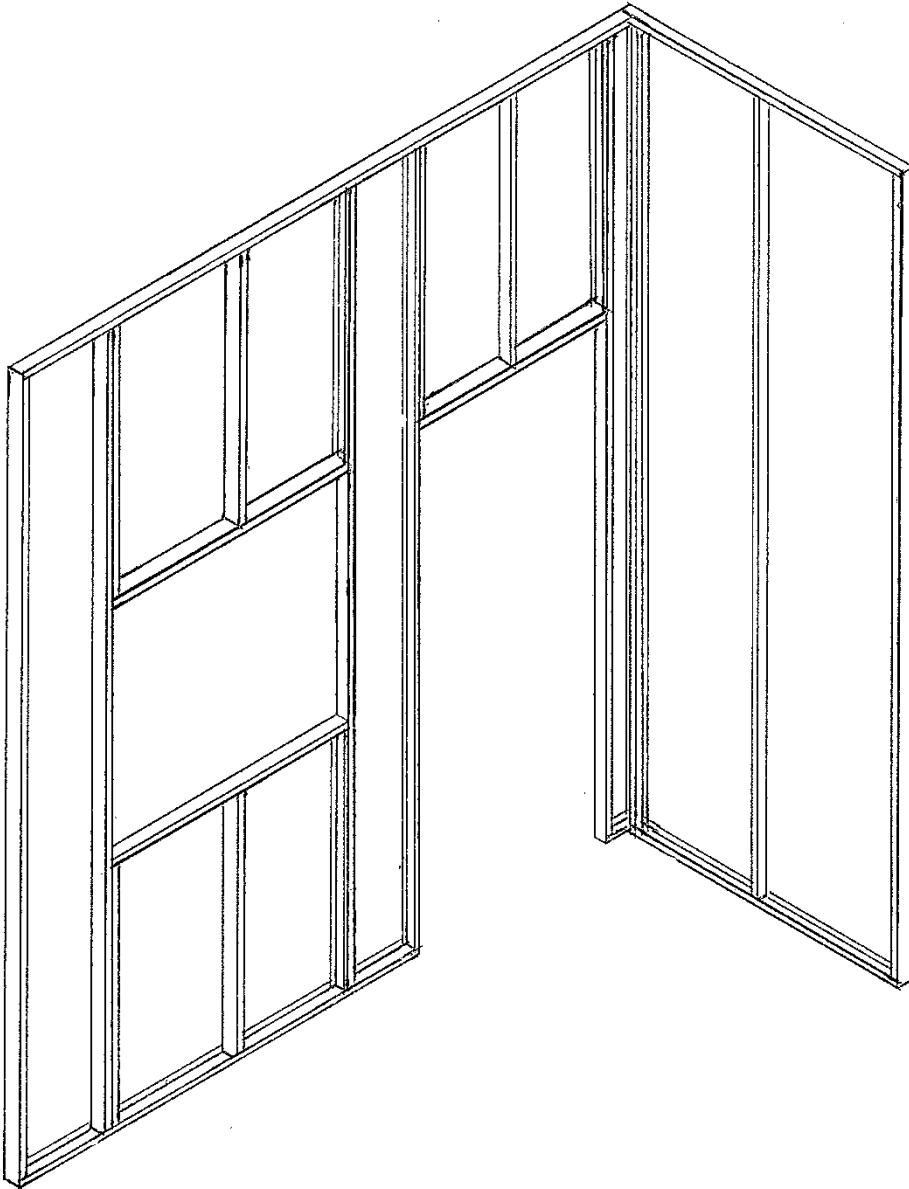

**Partition Installer (Metal Frame) Working Plan I
(Metal Frame Assembly Plan)**

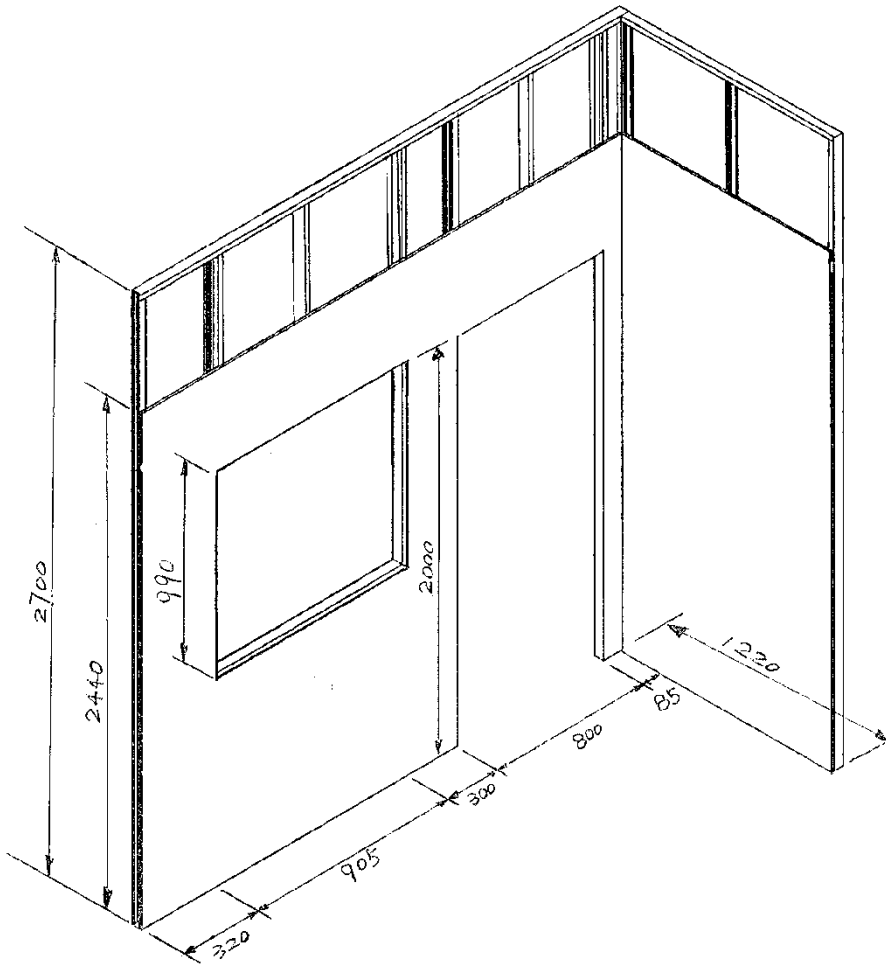

All measurements are in mm; this plan is not based upon the actual ratio.

**Partition Installer (Metal Frame) Working Plan II
(Gyp Board Assembly Plan)**

Specifications and Technical Requirements:

1. Tolerance of the vertical and horizontal levelling ink lines of the metal frame is $\cong 3\text{mm}$ (within the length of the component) ;
2. Gyp board cuts are accurate and smooth ($\cong 5\text{mm}$); and gyp boards are well composed and connected with joining space being $\cong 5\text{mm}$.
3. Gyp board screws to be installed correctly in sufficient quantity, and not exposed out of the board surface. Spaces between screws are 300 mm for the partition wall panels, and 200 mm for metal grid ceiling gyp panels, error tolerance being $\pm 50\text{mm}$; and screws that have penetrated gyp boards must be added.

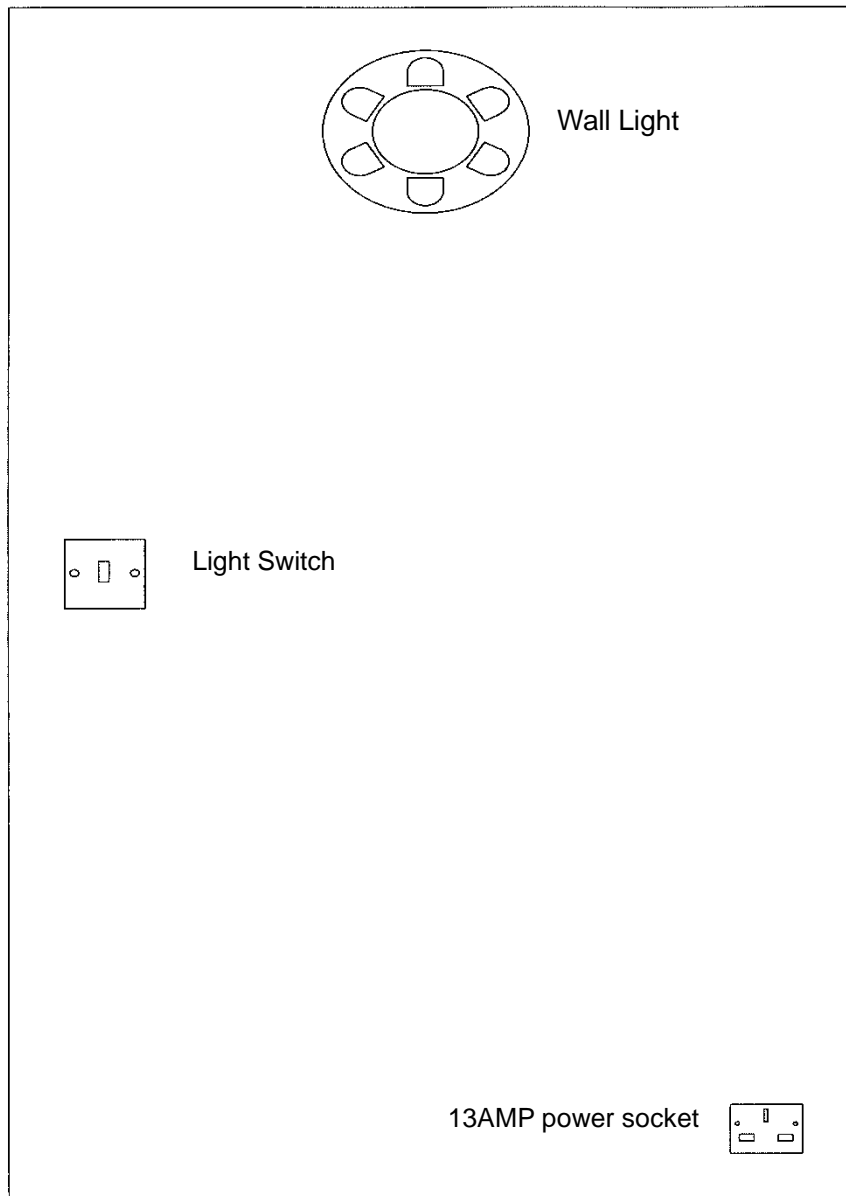

**Partition Installer (Metal Frame) Working Plan III
(Searching for Electric Pipeline)**

Specifications and Technical Requirements:

1. Search for hidden pipes with a detector at the designated location;
2. And mark the correct position and measurements (in millimeters) on the plan.

Notes to Candidates:

1. Candidates should read the test papers carefully and ask the invigilator for any queries.
2. Candidates should study the drawings and specifications attached to test papers, if any, before the test begins.
3. Candidates should carry out the test according to test papers, working drawings and specifications provided.
4. Candidates shall bring their own safety shoes, other safety equipment will be provided by trade testing centre. Candidates must take all necessary safety precautions to ensure work safety.
5. All tools and materials required by the test will be provided by trade testing centre, candidates should check and ensure their adequacy and quality. Candidates shall use the tools and materials properly based on trade practice. All the tools must be returned to trade testing centre after the test. The candidates may ask the invigilator for any problems.
6. Candidates are required to handle and move the tools and materials for use in the test, and to carry out associated works.
7. Invigilator will take record photos periodically during the test.
8. Candidates are not allowed to take any photo or video with cameras or mobile phones.
9. Candidates are not allowed to use their mobile phones during the trade tests, except for emergency situation.
10. The marking scheme is based on the following criteria :
 - a) Understanding of drawing and specification
 - b) Preparation works before commencement of test
 - c) Working procedures
 - d) Accuracy and quality of works
 - e) Progress of works
 - f) Proper handling and use of materials
 - g) Proper use of tools and equipment
 - h) Safety precautions

- i) Considerate of other trades
- h) Housekeeping after completion of test

11. All candidates must stop when time is up.
12. Candidates are required to return the test paper to invigilator after the test.
13. Offering bribe to invigilator is an offence in law and trade testing centre will report to the ICAC for any such case.

In the event that the candidate fails to take any necessary safety precautions and / or works in any dangerous situations, he / she will be assessed failed