



CONSTRUCTION
INDUSTRY COUNCIL
建造業議會

Joiner Skilled Trade Test Mock Written Test Paper

此文件關於細木大工工藝測試考題。如有需要索取此文件的中文版本，請致電 2100 9232 與工藝測試中心聯絡。

Disclaimer

No part of this material may be reproduced or transmitted in any form or any means without the written permission of the CIC. Whilst reasonable efforts have been made to ensure the accuracy of the information contained in this material, the CIC nevertheless would encourage readers to seek appropriate independent advice from their professional advisers where possible and readers should not treat or rely on this material as a substitute for such professional advice for taking any relevant actions.

Enquiries

Enquiries on this Material may be made to the Trade Test Centre at:

95, Yue Kwong Road
Aberdeen
Hong Kong

Tel: (852) 2100 9232
Fax: (852) 2100 9249
Email: enquiry@hkcic.org
Website: www.hkcic.org

© 2015 Construction Industry Council.

Please select the appropriate answer, each question has one answer only.

1. What is (x) ?

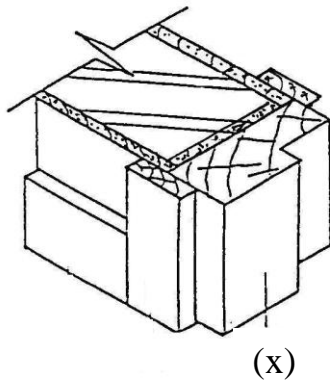

- (a) Skirting
- (b) Brickwall
- (c) Architrave
- (d) Jamb

2. What is the following figure :



- (a) Butt Joint
- (b) Halving Joint
- (c) Tongued & groove
- (d) Teeth Joint

3. Which of the following figure is "fibreboard" ?

- (a) 
- (b) 
- (c) 
- (d) 

4. Which part of the diagram names "Bark" ?

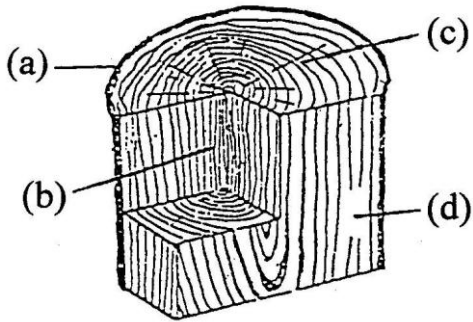

- (a)
- (b)
- (c)
- (d)

5. Which part of the figure is the length of "tenon" ?

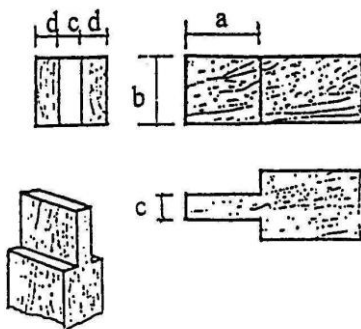

- (a)
- (b)
- (c)
- (d)

6. Which one of the following timber board shows "Warp" ?

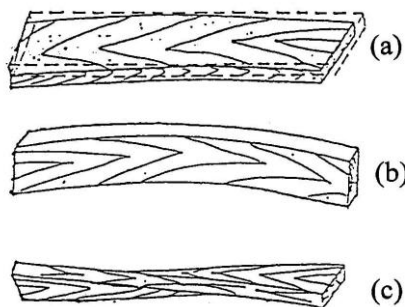

- (a)
- (b)
- (c)

7. Which is the right order for the following work process ?
- A. plane the edge of the plank
 - B. plane the surface of the plank
 - C. make the marking
 - D. use the marking gauge to draw out the applicated dimension
-
- a. BDAC
 - b. CDBA
 - c. DCBA
 - d. BACD
8. What is the normal distance between two core timber inside a hollow-flush door ?
- a. 50mm
 - b. 150mm
 - c. 300mm
 - d. 450mm
9. The most commonly used material for door frame is ?
- a. rose wood
 - b. walnut
 - c. camphor wood
 - d. pine wood
10. The width of door for bed-room must not be less than ?
- a. 500mm
 - b. 600mm
 - c. 700mm
 - d. 800mm

11. Which is the most dangerous position for spectator while the table circular saw is in operation ?

- a. in front of the operator
- b. back of the operator
- c. left-hand side of the operator
- d. right-hand side of the operator

12. The purpose of architrave on door frame is to :

- a. facilitate door-lock installation
- b. make the frame looks like thicker
- c. decorate the split between wall & jamb
- d. make a straight line for plastering

13. The reason not to nail the upper & lower brace at the same side of the door frame during assembly is for :

- a. increasing difficulty and upgrade the labour's technique
- b. looking more beautiful
- c. more steady, less transformation
- d. easier installation

14. The minimum height of fence for preventing following body from height is :

- a. 800mm
- b. 900mm
- c. 1000mm
- d. 1100mm

15. Definition of "Working at Height" means working at a level of :

- a. 1m above the ground
- b. 2m above the ground
- c. 3m above the ground
- d. 4m above the ground

16. The height of toeboard on scaffolding must not be lower than :
- a. 150mm
 - b. 200mm
 - c. 250mm
 - d. 300mm
17. What is the suitable length of nail to nail up a piece of 20mm timber into a 50mm plank ?
- a. 13mm
 - b. 25mm
 - c. 50mm
 - d. 75mm
18. The best position for "Hold-Fast" of a door frame :
- a. evenly distributed on the back side of the frame
 - b. as you like, no need to conceive about it
 - c. spread on the upper part of the jamb
 - d. install at the back side of hinge
19. Which kind of the following extinguisher is not suitable for putting out electrical fire ?
- a. Carbon dioxide
 - b. Dry powder
 - c. Clear water
 - d. Fire blanket
20. What is the purpose of "tool box talk" ?
- a. to serve the labours with a tea break
 - b. for labours to take a rest
 - c. report & discuss about the jobs
 - d. routine process to enhance the safety knowledge