



CONSTRUCTION  
INDUSTRY COUNCIL  
建造業議會

# Structural Steel Erector Skilled Trade Test Mock Practical Test Paper

此文件關於結構鋼架工工藝測試考題。如有需要索取此文件的中文版本，請致電 2100 9232 與工藝測試中心  
聯絡。

## **Disclaimer**

*No part of this material may be reproduced or transmitted in any form or any means without the written permission of the CIC. Whilst reasonable efforts have been made to ensure the accuracy of the information contained in this material, the CIC nevertheless would encourage readers to seek appropriate independent advice from their professional advisers where possible and readers should not treat or rely on this material as a substitute for such professional advice for taking any relevant actions.*

## **Enquiries**

Enquiries on this Material may be made to the Trade Test Centre at:

95, Yue Kwong Road  
Aberdeen  
Hong Kong

Tel: (852) 2100 9232  
Fax: (852) 2100 9249  
Email: [enquiry@cic.hk](mailto:enquiry@cic.hk)  
Website: [www.cic.hk](http://www.cic.hk)

© 2015 Construction Industry Council.

## Trade Test Paper

Trade : Structural Steel Erector

Skill Level : Skilled Worker

Question : Complete the following work at the specified location in the test venue:

1. Erect structural steel frame (85 marks)
  - i) Use appropriate tool to calibrate a temporarily installed H-shape steel column to correct verticality, and temporarily secure the column with the manual chain block (block) and wire rope (wire);
  - ii) Choose suitable lifting tool to safely lift a H-beam and a steel column respectively;
  - iii) Use bolt jointing method (螺栓接合法) to securely join the H-beam and steel column at the correct verticality and levelling with the steel column provided by the test venue, and secure the whole structure (please refer to "Drawing 1"); and
  - iv) Use a torque wrench to tighten the bolts to the torque strength required by the test in the correct sequence.
  
2. Cut metal component (15 marks)
  - i) Check the oxy-acetylene cutting tool and equipment;
  - ii) Set up the equipment according to correct safety procedure;
  - iii) Cut a 9 mm (thick) iron sheet according to the

- length provided by the test venue;
- iv) After completion, disassemble the oxy-acetylene tool and equipment and return them to the specified location; and
  - v) Clean up after completion, including tools and venue etc.

Test Time: 3 hours

- Notes:
- (1) The candidate must read the “Notes to Candidates” in the Annex before starting;
  - (2) If the candidate did not complete safety measures during the test, he/she will be deemed to have failed the test; and
  - (3) There are 3 pages in the question. All test items will have a full mark of 100 and 60 marks or above will be considered as pass.

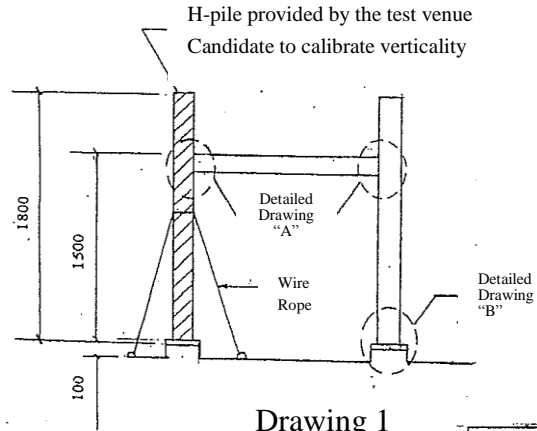

Drawing not in proportion  
Measurements in mm

Drawing 1

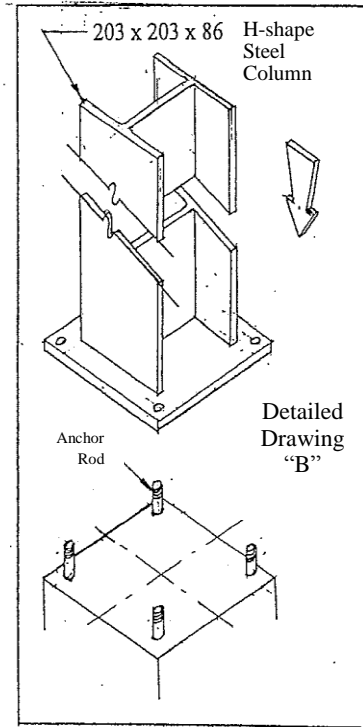
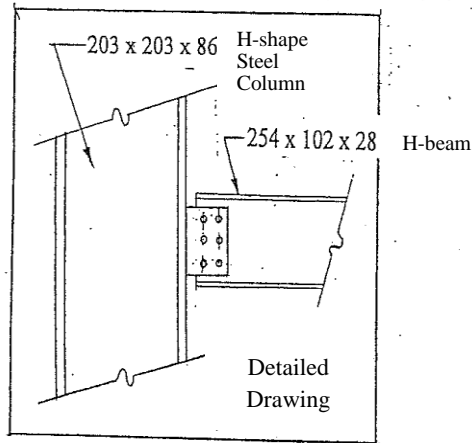

Notes to Candidates :

1. Candidates should read the test papers carefully and ask the invigilator for any queries.
2. Candidates should study the drawings and specifications attached to test papers, if any, before the test begins.
3. Candidates should carry out the test according to test papers, working drawings and specifications provided.
4. Candidates shall bring their own safety shoes, other safety equipment will be provided by trade testing centre. Candidates must take all necessary safety precautions to ensure work safety.
5. All tools and materials required by the test will be provided by trade testing centre, candidates should check and ensure their adequacy and quality. Candidates shall use the tools and materials properly based on trade practice. All the tools must be returned to trade testing centre after the test. The candidates may ask the invigilator for any problems.
6. Candidates are required to handle and move the tools and materials for use in the test, and to carry out associated works.
7. Invigilator will take record photos periodically during the test.
8. Candidates are not allowed to take any photo or video with cameras or mobile phones.
9. Candidates are not allowed to use their mobile phones during the trade tests, except for emergency situation.
10. The marking scheme is based on the following criteria :

- a) Understanding of drawing and specification
- b) Preparation works before commencement of test
- c) Working procedures
- d) Accuracy and quality of works
- e) Progress of works
- f) Proper handling and use of materials
- g) Proper use of tools and equipment
- h) Safety precautions
- i) Considerate of other trades
- h) Housekeeping after completion of test

- 11. All candidates must stop when time is up.
- 12. Candidates are required to return the test paper to invigilator after the test.
- 13. Offering bribe to invigilator is an offence in law and trade testing centre will report to the ICAC for any such case.

**In the event that the candidate fails to take any necessary safety precautions and / or works in any dangerous situations, he / she will be assessed failed**