



CONSTRUCTION
INDUSTRY COUNCIL
建造業議會

Bar Bender & Fixer Intermediate Trade Test Mock Practical Test Paper

此文件關於鋼筋屈紮工工藝測試考題。如有需要索取此文件的中文版本，請致電 2100 9232 與工藝測試中心聯絡。

Disclaimer

No part of this material may be reproduced or transmitted in any form or any means without the written permission of the CIC. Whilst reasonable efforts have been made to ensure the accuracy of the information contained in this material, the CIC nevertheless would encourage readers to seek appropriate independent advice from their professional advisers where possible and readers should not treat or rely on this material as a substitute for such professional advice for taking any relevant actions.

Enquiries

Enquiries on this Material may be made to the Trade Test Centre at:

95, Yue Kwong Road

Aberdeen

Hong Kong

Tel: (852) 2100 9232

Fax: (852) 2100 9249

Email: enquiry@hkcic.org

Website: www.hkcic.org

Intermediate Trade Test Paper

- Trade : Bar Bender & Fixer
- Grade : Semi-skilled worker
- Test Content : 1. Fixing of reinforcement structure according to materials are provided C1 column, W1 wall and S1 Slab. (80 marks)
2. Use machinery to cut and bend Y10 reinforcement in U shape. (10 marks)
3. Use a bending machine to bend Y16 reinforcement. (10 marks)
- Duration : 3 Hours
- Notes : (1) Candidate should read the attached “Notes to Candidates” before commencement of work.
- (2) Candidate will be marked as fail if he / she does not carry out safety precautions during the test.
- (3) The test paper consists of 6 pages. Total mark is 100. Passing mark is 60.

Test 1 : Fixing of Reinforcement

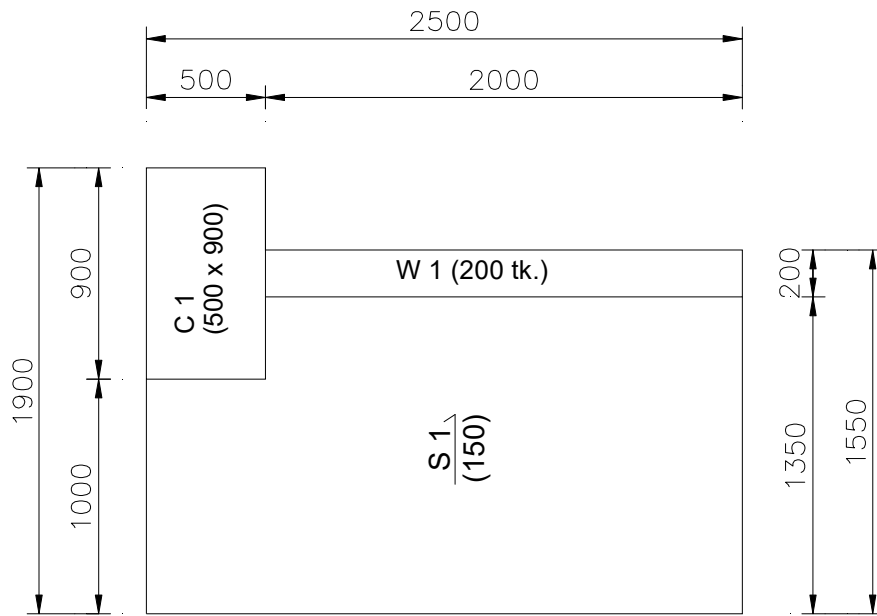

PLAN

Test 2 : Cut & Bend U Shape Rebar

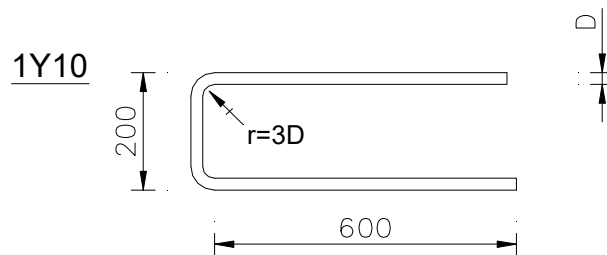

Test 3 : Cut and Bend Single Hook

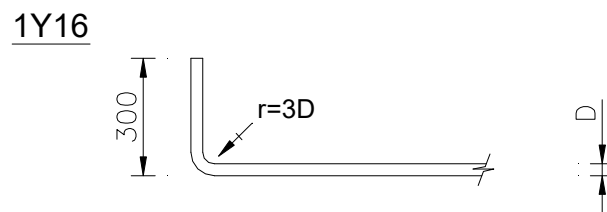

Not to scale
All dimensions are in mm

Test1 : Column

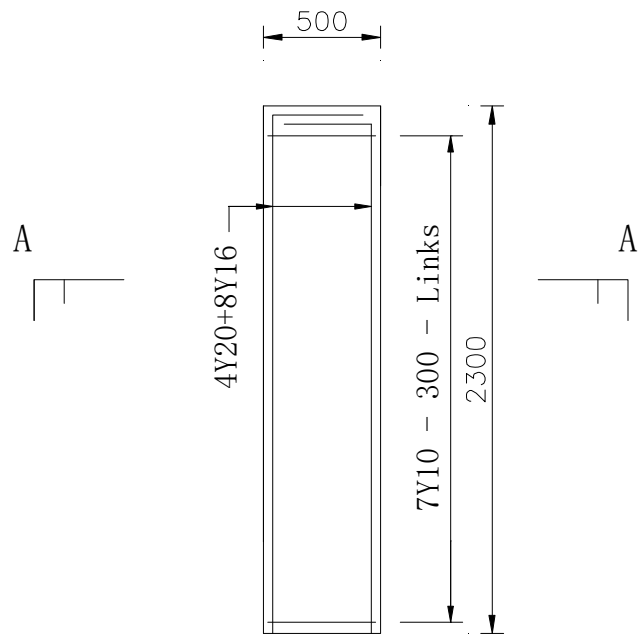

ELEVATION

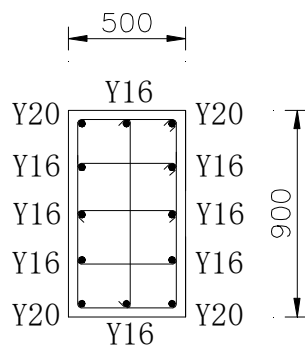

Sec A-A

Not to scale
All dimensions are in mm

Test 1 : Wall

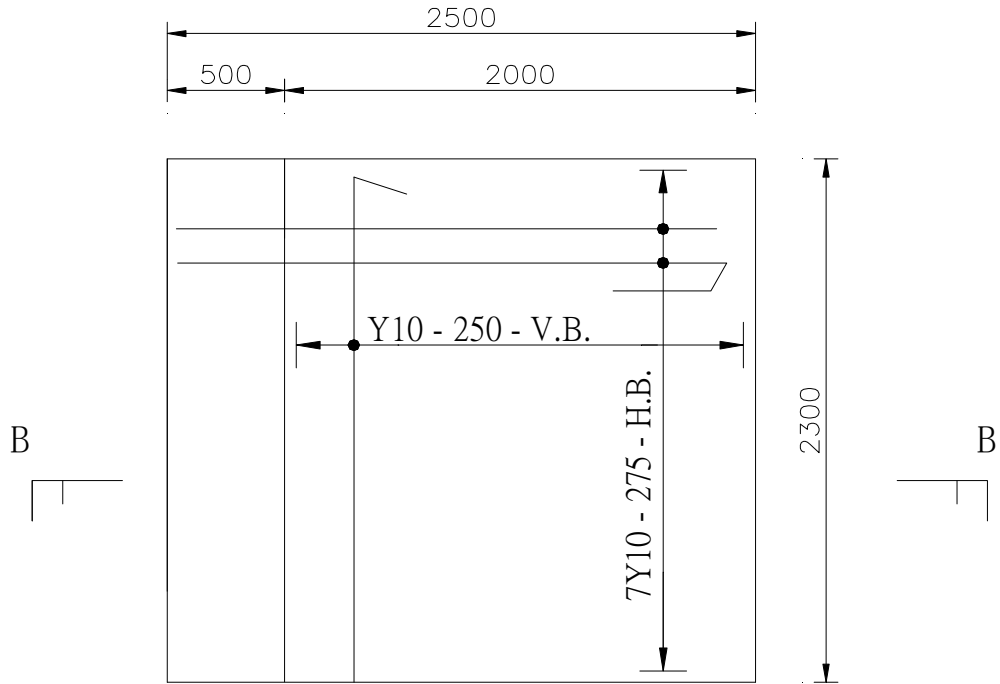

ELEVATION

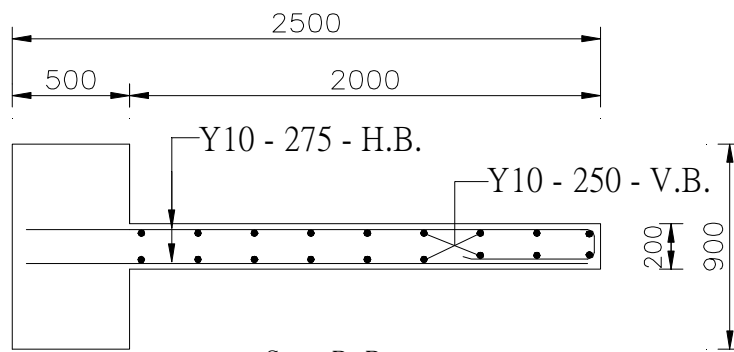

Sec B-B

Not to scale
All dimensions are in mm

Test 1 : Slab

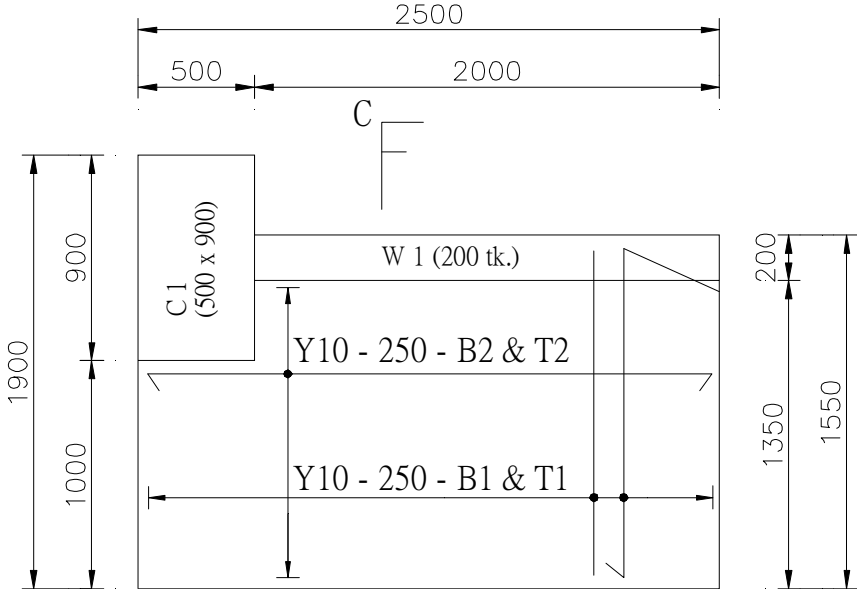

PLAN

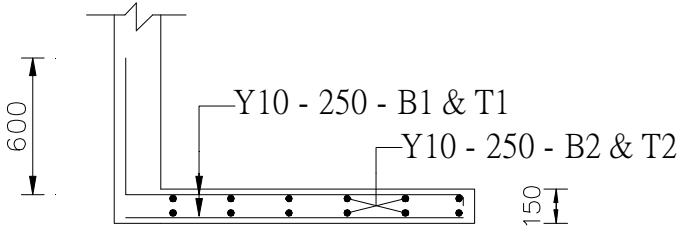
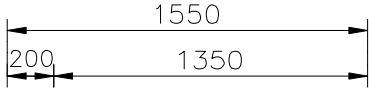
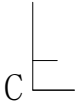

Sec C-C

Not to scale
All dimensions are in mm

Notes to Candidates :

1. Candidates should read the test papers carefully and ask the invigilator for any queries.
2. Candidates should study the drawings and specifications attached to test papers, if any, before the test begins.
3. Candidates should carry out the test according to test papers, working drawings and specifications provided.
4. Candidates shall bring their own safety shoes, other safety equipment will be provided by trade testing centre. Candidates must take all necessary safety precautions to ensure work safety.
5. All tools and materials required by the test will be provided by trade testing centre, candidates should check and ensure their adequacy and quality. Candidates shall use the tools and materials properly based on trade practice. All the tools must be returned to trade testing centre after the test. The candidates may ask the invigilator for any problems.
6. Candidates are required to handle and move the tools and materials for use in the test, and to carry out associated works.
7. Invigilator will take record photos periodically during the test.

8. Candidates are not allowed to take any photo or video with cameras or mobile phones.
9. Candidates are not allowed to use their mobile phones during the trade tests, except for emergency situation.
10. The marking scheme is based on the following criteria :
 - a) Understanding of drawing and specification
 - b) Preparation works before commencement of test
 - c) Working procedures
 - d) Accuracy and quality of works
 - e) Progress of works
 - f) Proper handling and use of materials
 - g) Proper use of tools and equipment
 - h) Safety precautions
 - i) Considerate of other trades
 - h) Housekeeping after completion of test
11. All candidates must stop when time is up.
12. Candidates are required to return the test paper to invigilator after the test.
13. Offering bribe to invigilator is an offence in law and trade testing centre will report to the ICAC for any such case.

In the event that the candidate fails to take any necessary safety precautions and / or works in any dangerous situations, he / she will be assessed failed