

# General Welder Intermediate Trade Test Practical Test Mock Paper

( Version : IGW-PM-EN-01 )



此文件關於普通焊接工中級工藝測試實務測試模擬試題。

如需索取此文件的中文版本，請致電 2100 9000 與香港建造業工藝測試中心聯絡。

## Disclaimer

No part of this material may be reproduced or transmitted in any form or by any means without the written permission from the Construction Industry Council (CIC). Whilst reasonable efforts have been made to ensure the accuracy of the information contained in this material, the CIC nevertheless would encourage readers to seek appropriate independent advice from their professional advisers where possible and readers should not treat or rely on this material as a substitute for such professional advice for taking any relevant actions. The CIC will not assume any liability in relation to any loss or damage directly or indirectly resulted from unintended or/and unforeseeable use of this document.

This document is provided as reference for test preparation only. Under all circumstances all content in the official test papers, including but not limited to the terms and conditions therein, prevails.

The CIC reserves the right, at its sole and absolute discretion, to change, update or delete the contents in this document at any time without prior notice.

The CIC reserves all rights of final interpretation for any content in this document.

## Enquiries

Enquiries on this material may be made to Hong Kong Construction Industry Trade Testing Centre (HKCITTC) at:

Address: 95 Yue Kwong Road, Aberdeen, Hong Kong

Tel: (852) 2100 9000

Fax: (852) 2100 9090

Email: [hkcittc@cic.hk](mailto:hkcittc@cic.hk)

Website: [www.cic.hk](http://www.cic.hk)

# General Welder Intermediate Trade Test

## Practical Test Mock Paper

**Trade:** General Welder

**Grade:** Semi Skilled Worker

**Test Content:** Complete the following items at designated location:

1. Select suitable electrode, adjust current, fix the steel plates by tack weld and full weld in flat position.
2. Set up & check cutting device properly, adjust the pressure and light. Cut the work piece according to the lines. Upon completion, disassemble the cutting device.

**Duration:** 3 hours

**Notes:**

- (1) Candidate should read the attached “Notes to Candidate” before commencement of work and comply with all test related rules and requirements.
- (2) To achieve overall “Pass” grade in practical test of trade test, candidates should satisfy ALL testing requirements as stated below:
  - obtain “Pass” grade in technical skill section (i.e. achieve minimum 60 marks out of 100 marks, and no serious mistakes made in technical aspect and at works during the test,
  - meet the specific requirement(s) in specified item(s) of assessment criteria, and
  - obtain “Pass” grade in safety assessment (remarks: candidates will be deemed as candidates will be deemed as “Fail” if he/she fails to carry out necessary safety precautionary actions during the test).
- (3) For the details of assessment criteria for practical test, please refer to “Introductory booklet for General Welder Intermediate Trade Test”.

### **Precautions**

This document is provided as reference for test preparation only. Under all circumstances all content in the official test papers, including but not limited to the terms and conditions therein, prevails. There are different versions of the test paper, content include but not limited to tools, materials, equipment, drawing, construction details or procedures and different simulated site environments. Candidates should refer to the official test documents during testing.

The CIC reserves the right, at its sole and absolute discretion, to change, update or delete the contents in this document at any time without prior notice.

## Drawing No. 1 for General Welder Intermediate Trade Test

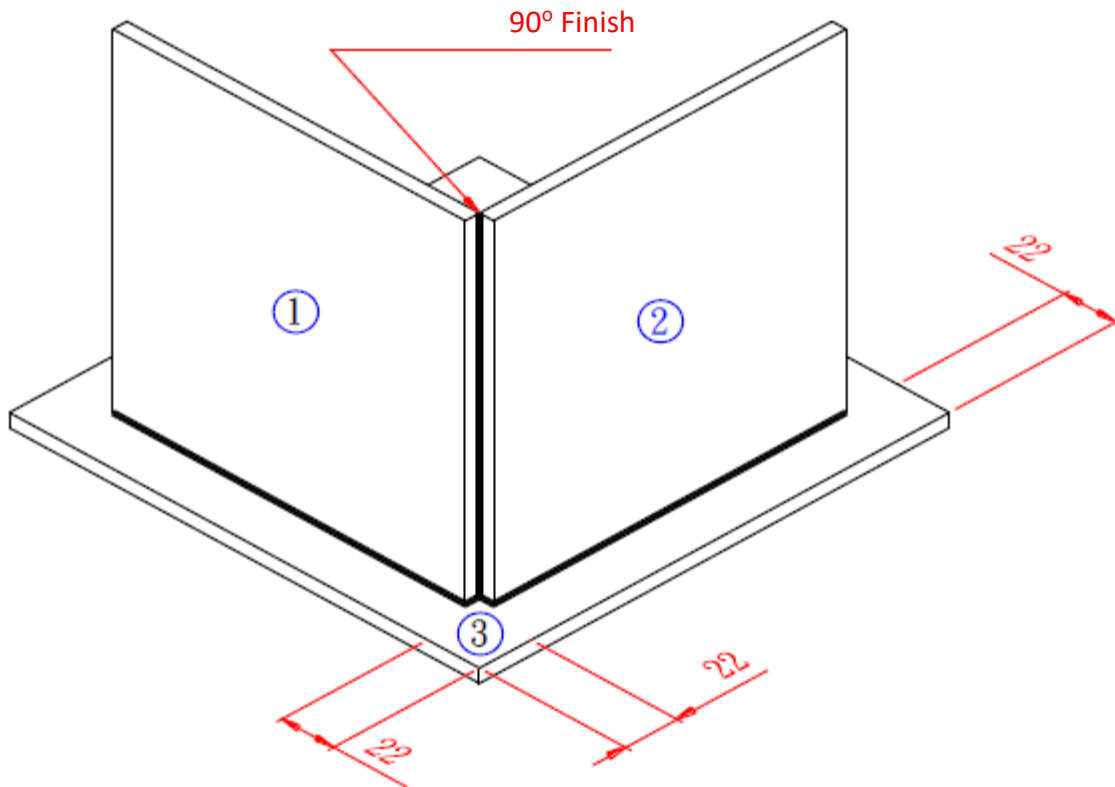

Drawing not to scale.  
All dimensions are in mm.

### Specifications and Requirements

1. Weld in flat position after the work pieces have been connected by tack weld.
2. All welds are full weld.
3. Leg length 5mm to 8mm.
4. All welds shall be free from defects.
5. Upon completion, remove all slags and spatters.

Material	Dimensions/ Specification
Mild Steel Plate	150 x 150 x 6
Mild Steel Plate	200 x 200 x 6
Electrode	E6013, $\varnothing$ 3.2

## Drawing No. 2 for General Welder Intermediate Trade Test

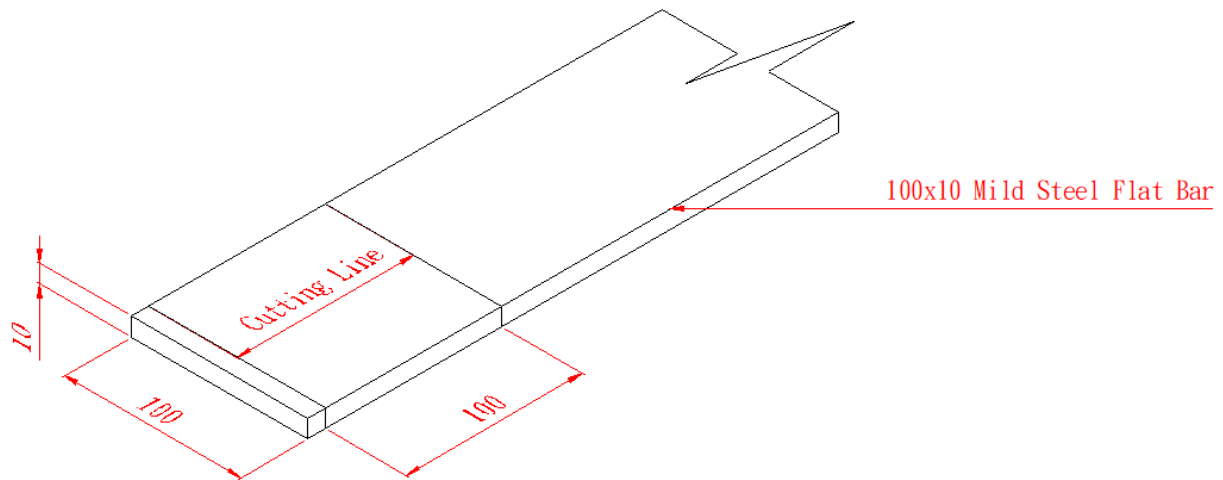

Drawing not to scale.  
All dimensions are in mm.

### **Specifications and Requirements**

1. Cut the work piece along the lines drawn on the plate.
2. Candidate is required to work on floor.
3. Tolerance of kerf's straightness shall not exceed 3mm.
4. Width of kerf shall not exceed 4mm.
5. Perpendicular of kerf shall not exceed 2.5mm.
6. The slag attached on the bottom of kerf shall be removed.

## Notes to Candidate

1. Candidates should read the test papers carefully and ask the invigilator for any queries.
2. Practical test making scheme is based on the following criteria:
  - a. Understanding of drawing and specification
  - b. Preparation works before commencement of test
  - c. Working procedures, accuracy, quality of works and progress of works
  - d. Proper handling and use of materials
  - e. Proper use of tools and equipment
  - f. Housekeeping after completion of test
  - g. Safety precautions
3. Candidates should study the drawings and specifications attached to the test paper, if any, before the test begins.
4. Candidates should carry out the test according to test papers, working drawings and specifications provided.
5. Candidates shall bring their own safety shoes and appropriate workwear, other safety equipment will be provided by HKCITTC. Candidates must take all necessary safety precautions to ensure work safety.
6. All tools and materials required by the test will be provided by HKCITTC, candidates should check and ensure their adequacy and quality. All the tools must be returned to HKCITTC after the test. The candidates may ask the invigilator for any problems.
7. Candidates are required to handle and move the tools and materials for use in the test, and to carry out associated works.
8. All candidates must stop when time is up.
9. Candidates are required to return the test paper to invigilator after the test.
10. Invigilator will take record photos periodically during the test.
11. Candidates are not allowed to take any photo or video with cameras or mobile phones.
12. Candidates are not allowed to use their mobile phones during the trade tests, except for emergency situation.
13. Offering bribe to invigilator is an offence in law and HKCITTC will report to the ICAC for any such case.
14. Subject to certain situations and/or conditions of the date of event, trade tests/courses could be at any moment suspended or postponed at discretion of the invigilators. Examples of such situation/condition could be, but not limited to, (a) sudden operation disruptions to classrooms, test venues, test equipment or tools etc. due to unforeseeable mishaps; (b) sickness or injury of candidates, students or elated staff of the HKCITTC; (c) adverse weather condition. The HKCITTC will rearrange another appointment, for free, with the candidates/students affected. Whilst every effort is made to ensure the smooth running of trade test/courses, the HKCITTC will not resume any liability any loss/damage directly or indirectly related to such arrangement.

In the event that the candidate fails to take any necessary safety precautions and / or works in any dangerous situations, he / she will be assessed failed.