



CONSTRUCTION  
INDUSTRY COUNCIL  
建造業議會

# Mechanic Fitter Trade Test Mock Practical Test Paper

此文件關於機械打磨裝配工技能測試考題。如有需要索取此文件的中文版本，請致電 2100 9000 與香港建造業工藝測試中心聯絡。

## **Disclaimer**

*No part of this material may be reproduced or transmitted in any form or any means without the written permission of the CIC. Whilst reasonable efforts have been made to ensure the accuracy of the information contained in this material, the CIC nevertheless would encourage readers to seek appropriate independent advice from their professional advisers where possible and readers should not treat or rely on this material as a substitute for such professional advice for taking any relevant actions.*

## **Enquiries**

Enquiries on this Material may be made to the Hong Kong Construction Industry Trade Testing Centre at:

95, Yue Kwong Road  
Aberdeen  
Hong Kong

Tel: (852) 2100 9000  
Fax: (852) 2100 9090  
Email: [enquiry@cic.hk](mailto:enquiry@cic.hk)  
Website: [www.cic.hk](http://www.cic.hk)

© 2021 Construction Industry Council.

## Test Paper for Trade Test

Job Title : Mechanic Fitter

Skill Level : Skilled worker

Test : Complete the practical tasks below at the specified location:

(Please refer to the work drawing)

1. Using the belt distributed by the test venue (designated length), calculate the distance between two belt reels;
2. According to rated rotating speed of the motor and the required output rotating speed ( $\pm 5\%$ ), calculate the ratio of the two gears and pick the gears with the correct number of teeth;
3. Use an appropriate method to produce an axis pin and install the gears;
4. Use an appropriate method to position, drill a hole and make a round pit on an iron plate (thickness: 5mm), so as to fix the ball bearing and install it according to the size of the gears;
5. Use an appropriate method to position, drill a hole and make a round pit on an iron plate (thickness: 5mm), so as to secure the motor and install properly according to the distance and straight line between the two belt reels;
6. Use an appropriate method to position, drill a hole and tap (M12×1.75mm) on an iron plate (thickness: 10mm), and use it to fix the bolts provided by the test venue (M12×1.75mm);
7. Arc weld the tapped 10mm iron plate and the 5mm iron plate supporting the motor;
8. Adjust the bolt (M12×1.75mm) to tighten the belt.
9. Install safety shields (provided by the test venue).

- ◆ Full score of the test is 100. Candidates must score not less than 60 marks to pass the practical test.

Time Limit: Three hours

Points to note:

- 1) Before you start, read all “Instructions for Candidates” below and the “Rules at the Test Venue” distributed at the venue.
- 2) You will fail the test if you do not take proper safety measures during the test.
- 3) After the test, clean up the venue and restore its original condition as instructed by the invigilators.
- 4) Candidates should wear appropriate protective goggles and gloves when welding.

## Work drawing

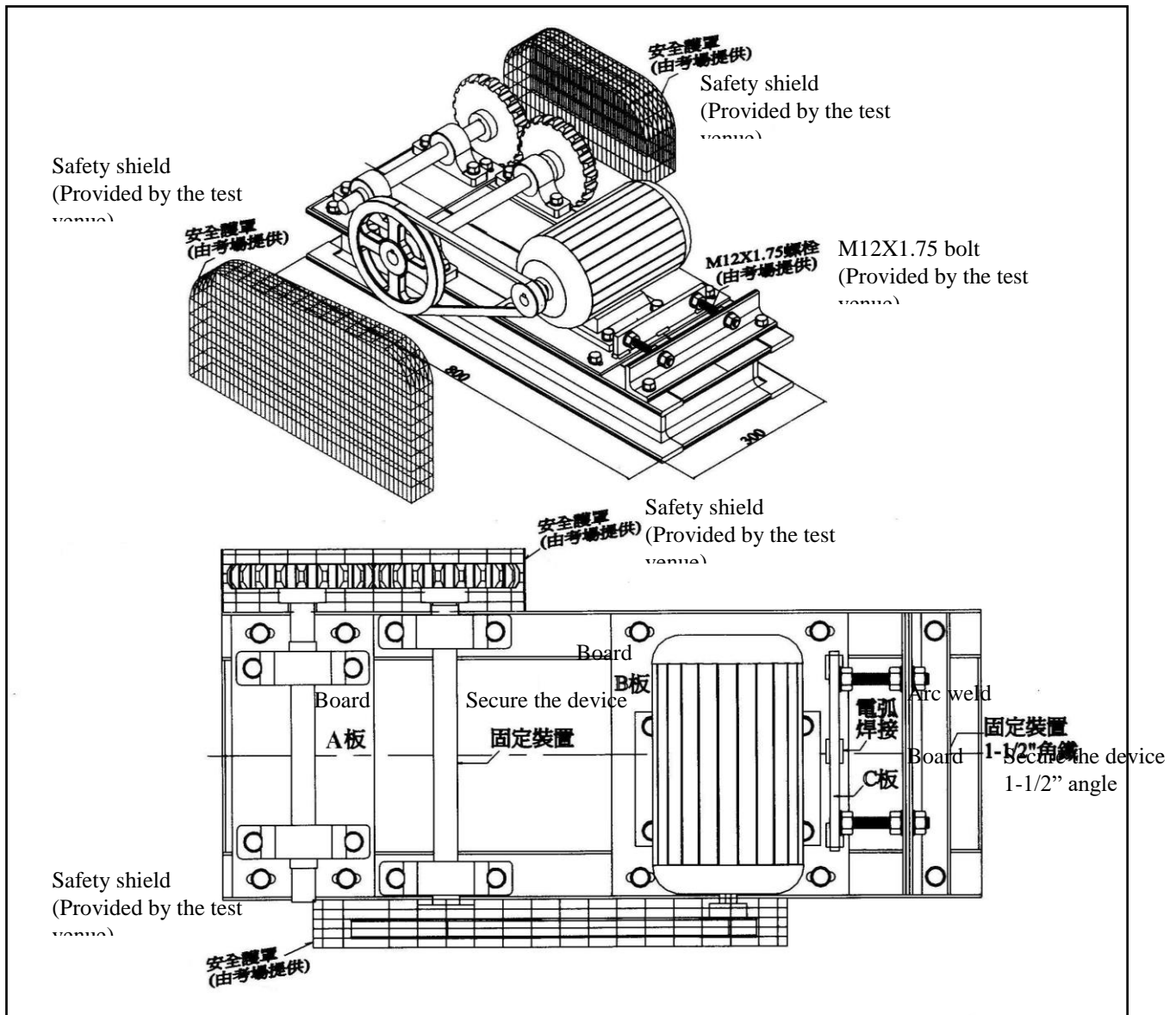

### Notes:

1. Before you start, you must read carefully the size details provided by the test venue.
2. Candidates should determine the distance between the two wheel axes, according to the actual situation.
3. Candidates should determine the distance between the motor and the “fixed device”, according to the actual size of the belt distributed by the test venue.
4. Candidates should determine the location and size of the long hole on board A, while the tapping of the bearing housing fixing hole is M10X1.5.
5. Candidates should determine the location and size of the long hole on board B, while tapping of the motor housing fixing hole is M10X1.5.
6. The location of the M12X1.75 tapped hole on board C should match the 1-1/2” angle bar at the fixed device.
7. Using the materials supplied by the test venue, install suitable safety shields firmly.

Notes to Candidates :

1. Candidates should read the test papers carefully and ask the invigilator for any queries.
2. Candidates should study the drawings and specifications attached to test papers, if any, before the test begins.
3. Candidates should carry out the test according to test papers, working drawings and specifications provided.
4. Candidates shall bring their own safety shoes, other safety equipment will be provided by trade testing centre. Candidates must take all necessary safety precautions to ensure work safety.
5. All tools and materials required by the test will be provided by trade testing centre, candidates should check and ensure their adequacy and quality. Candidates shall use the tools and materials properly based on trade practice. All the tools must be returned to trade testing centre after the test. The candidates may ask the invigilator for any problems.
6. Candidates are required to handle and move the tools and materials for use in the test, and to carry out associated works.
7. Invigilator will take record photos periodically during the test.
8. Candidates are not allowed to take any photo or video with cameras or mobile phones.
9. Candidates are not allowed to use their mobile phones during the trade tests, except for emergency situation.
10. The marking scheme is based on the following criteria :
  - a) Understanding of drawing and specification
  - b) Preparation works before commencement of test
  - c) Working procedures
  - d) Accuracy and quality of works
  - e) Progress of works
  - f) Proper handling and use of materials
  - g) Proper use of tools and equipment
  - h) Safety precautions
  - i) Considerate of other trades
  - j) Housekeeping after completion of test
11. All candidates must stop when time is up.
12. Candidates are required to return the test paper to invigilator after the test.
13. Offering bribe to invigilator is an offence in law and trade testing centre will report to the ICAC for any such case.

**In the event that the candidate fails to take any necessary safety precautions and / or works in any dangerous situations, he / she will be assessed failed**